



Product Information

Model: DG, DL, DLG, DM, DMG, DE, DEG
Burner Sizes: 145, 175

GENERAL DESCRIPTION

The D/Series gas, oil, and combination gas/oil burner is a forced draft packaged burner system. A backward curved aluminum impeller mounted in a machined housing provides combustion air for various furnace pressures or high altitude applications. The air housing is hinged for convenient inspection or service of the firing head components.

Oil firing features low pressure air atomizing design. A positive displacement oil metering unit, rotary vane air compressor, and air atomizing nozzle are integral parts of this system. The positive displacement oil metering unit is not affected by changes in oil temperature or viscosity.

Efficient gas combustion is attained by entering gas through ports ahead of the diffuser providing superior mixing of gas

and air. Excellent flame retention is assured at all firing rates. A gas manifold is provided on all oil burners for future addition of gas.

Combination gas/oil burners change from one fuel to the other by simply flipping a switch. No burner modifications or readjustment are required when changing from one fuel to the other.

Listed by Underwriters Laboratory. CSD-1, I.R.I., F.M., C.S.A. and other regulatory agency control options are available. Every burner is assembled, wired, and tested at the factory. Compressor modules and main gas train components are shipped loose.

U.L. STANDARD EQUIPMENT

A. CONTROLS

1. 120/1/60 control circuit
2. Burner mounted control panel
3. Motor starter(s)
4. Panel signal lights (4) (See Note 4)
5. Full Modulation with manual potentiometer (135 ohm)
6. Fuel changeover switch (combination gas/oil models)
7. Flame safeguard controls (See Note 1)
8. Combustion air proving switch
9. High fire air interlock switch

B. OIL SYSTEM

1. Burner mounted oil metering system
2. Burner mounted integral atomizing air compressor (D145 Except models DE-DEG)
3. Separate air compressor module (DE, DEG) and all D175
4. Air/lube oil reservoir
5. Fuel oil strainer (burner)
6. Oil solenoid valve
7. S.S.O. oil solenoid valve with relief valve
8. High oil temp switch mounted. (DM, DMG, DE, DEG)
9. Low oil pressure switch (DE, DEG) and all models D175
10. Atomizing air interlock switch
11. Nozzle line heater w/cold oil lockout (DM, DMG, DE, DEG)

C. MAIN GAS SYSTEM (See Note 2)

1. Butterfly rate control valve
2. One motorized valve with closure interlock and one solenoid valve motorized
3. N.O. vent valve
4. Gas shutoff cocks(2)
5. Main gas regulator
6. High and low gas pressure switches

D. GAS PILOT SYSTEM

1. Gas-electric interrupted pilot
2. Shutoff cock
3. Separate pilot regulator and valve

E. OTHER EQUIPMENT

1. 3450 rpm blower motor and aluminum impeller
2. Burner mounting flange
3. Refractory combustion cone and gasket
4. Hinged, swing-away air housing
5. Rotary air damper w/silencer
6. Bolt On Firing head
7. Gas manifold is standard on all oil burners for future gas firing
8. Cam Trim U.L. listed

F. OPTIONAL EQUIPMENT

1. Plant atomizing air system using air regulating assembly
2. Steam atomization system with steam regulating assembly

NOTES

1. Lead sulphide scanner standard. U.V. optional.
2. All main gas line valves and accessories upstream of butterfly valve are shipped loose.
3. Standard motor voltages are 208-230-460/3/60. Totally enclosed and 50 cycle motors are optional.
4. Signal lights: Power On, Main Fuel, Ignition, and Flame Failure.
5. A separate oil circulating pump set is required for all oil and combination fuel burners. The burner mounted unit is an oil input metering device only.

ORDERING INFORMATION (Specify)

1. Burner voltage, phase and cycle (See Note3)
2. Control Circuit Voltage (120/1/60)
3. Burner model and actual firing rate
4. Flame Safeguard Control
5. Special Code and/or Insurance Requirements
6. Available Gas Pressure

Type of fuel determines the model designation	
Model	Fuel
DG	Gas
DL	No. 2 Oil
DLG	No. 2 Oil / Gas
DM	No. 2-5 Oil
DMG	No. 2-5 Oil / Gas
DE	No. 2-6 Oil
DEG	No. 2-6 Oil / Gas

CAPACITIES AND SPECIFICATIONS	BURNER SIZE	
	145	175
GAS INPUT (Mbtu/hr)(See Note 1)	15,000	17,500
OIL INPUT (U.S.G.P.H.)(See Note 2)	107	125
BOILER HP @ 80% EFF.(See Note 3)	357	417
GAS MANIFOLD PRESSURE (in.W.C.)(See Note 4)	4	4
BLOWER MOTOR HP - S Model (See Note 5)	15	20
BLOWER MOTOR HP - P Model (See Note 5)	15	20
OIL METERING UNIT MOTOR HP (DE-DEG)(D175 to D420)	1/2	1/2
AIR COMPRESSOR MOTOR HP (DE-DEG)(D175 TO D420)	3	5
INTEGRAL AIR/OIL UNIT MOTOR HP (DL-DLG to 145)	2	-
INTEGRAL AIR/OIL UNIT MOTOR HP (DM-DMG to 145)	2	-
NOZZLE LINE HEATER (KW)(DM-DMG-DE-DEG)	5	5
APPROX. SHIPPING WEIGHT (Lbs)	1,500	1,800

Notes:

1. Gas input based on natural gas at 1,000 Btu/cu.ft. and 0.60 gravity.
2. Oil input based on NO. 2 oil at 140,000 Btu/gal.
3. Boiler overall efficiency of 80% estimated.
4. Gas pressure based on zero furnace pressure. For total pressure at manifold, add furnace pressure.
5. Impeller and motor HP is based on altitude up to 2,000 ft. above seal level.
 For higher altitude or 50 Hz applications, consult factory.
 Use model "S" up to 1.5" w.c. furnace pressure
 Use model "P" up to 4" w.c. furnace pressure
 Standard motor voltages are 208-230-460/3/60

GENERAL DIMENSIONS

CONTROL PANEL DIMENSIONS
19-1/2" x 23-1/2" x 6-1/2"

JUNCTION BOX DIMENSIONS
14-1/8" x 16-1/8" x 7-3/8"

SEPARATE COMPRESSOR DIMENSIONS

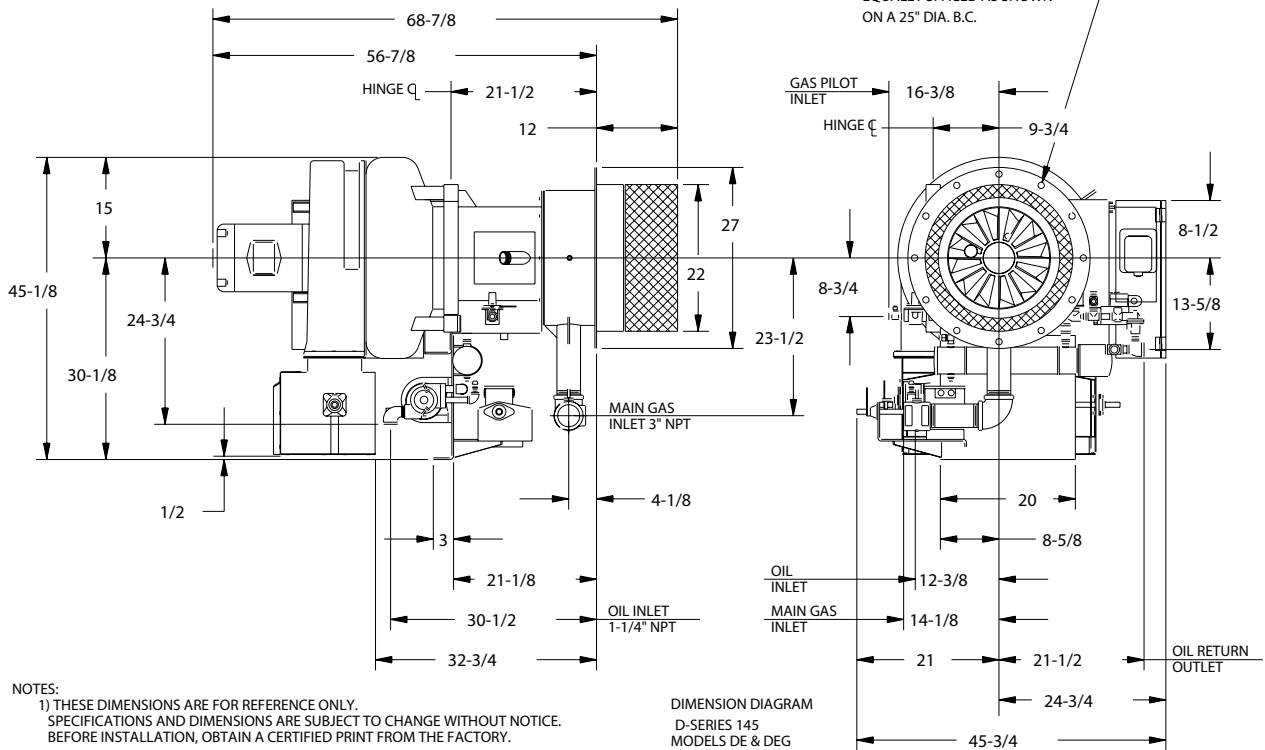
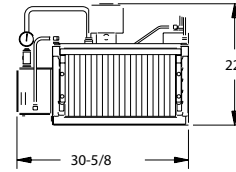
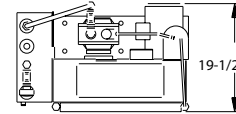
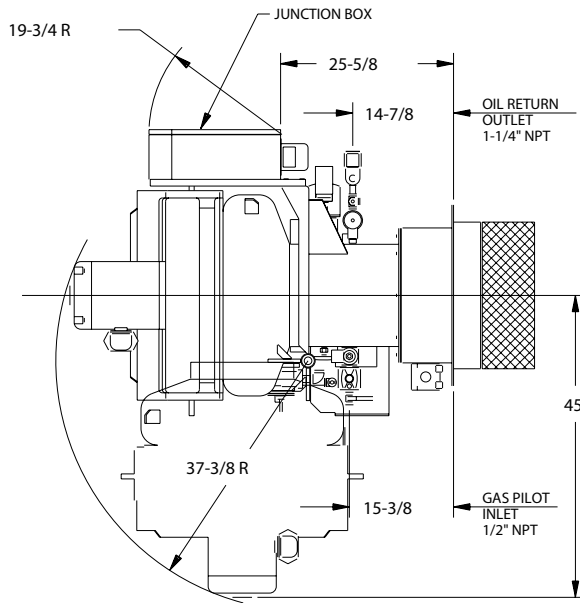

NOTES:
1) THESE DIMENSIONS ARE FOR REFERENCE ONLY.
SPECIFICATIONS AND DIMENSIONS ARE SUBJECT TO CHANGE WITHOUT NOTICE.
BEFORE INSTALLATION, OBTAIN A CERTIFIED PRINT FROM THE FACTORY.

DIMENSION DIAGRAM
D-SERIES 145
MODELS DE & DEG

GENERAL DIMENSIONS

CONTROL PANEL DIMENSIONS
19-1/2" x 23-1/2" x 6-1/2"

JUNCTION BOX DIMENSIONS
14-1/8" x 16-1/8" x 7-3/8"

SEPARATE COMPRESSOR DIMENSIONS

