



Product Information

Model: KG, KL, KLG

Burner Sizes: 13, 17, 21, 25

GENERAL DESCRIPTION

The ProFire K/Series gas, oil, and combination gas/oil burner is a forced draft packaged burner system. A backward curved aluminum impeller mounted in a machined housing provides combustion air for various furnace pressures or high altitude applications.

KG gas burners, burn gas under a controlled gas/air pressure mix. Gas is emitted from jets surrounding the air stream, producing a turbulent mixture which burns quietly and efficiently.

KL oil burners incorporate a high pressure atomizing design using simplex nozzles. A directly driven fuel oil pump is burner mounted. Consistent fuel/air ratio is maintained regardless of firing rate.

KLG combination gas/oil burners change from one fuel to the other by simply flipping a switch. No burner modifications or readjustment are required when changing from one fuel to the other.

Listed by Underwriters Laboratory. CSD-1, I.R.I., F.M., and other regulatory agency control options are available.

Every ProFire burner is assembled, wired, and tested at the factory.

U.L. STANDARD EQUIPMENT

A. CONTROLS

1. 120/1/60 control circuit
2. Burner mounted control panel
3. Motor starter(s)
4. Panel signal lights (4) (See Note 4)
5. Low-High-Off firing
6. Fuel changeover switch (combination gas/oil models)
7. Flame safeguard controls (See Note 1)
8. Combustion air proving switch
9. Ignition transformer

B. OIL SYSTEM

1. Two stage fuel unit, directly driven
2. Simplex oil nozzle
3. Oil solenoid valve
4. S.S.O. oil solenoid valve
5. Oil metering valve
6. Fuel oil strainer (shipped loose)

C. MAIN GAS SYSTEM (See Note 2)

1. Butterfly rate control valves
2. One motorized valve and one solenoid valve
3. Gas shutoff cocks (2)
5. Main gas regulator

D. GAS PILOT SYSTEM

1. Gas-electric interrupted pilot (KG, KLG)
2. Shutoff cock
3. Separate pilot regulator and valve
4. Direct spark ignition (KL)

E. OTHER EQUIPMENT

1. 3450 rpm blower motor and aluminum impeller
2. Burner mounting flange

3. Gas manifold is standard on all oil burners for future gas firing

F. OPTIONAL EQUIPMENT

1. Control circuit transformer
2. Separately driven remote oil pump set
3. Low-High-Low or full modulation
4. Inverted housing arrangement

NOTES

1. U.V. scanner standard.
2. All main gas line valves and accessories upstream of butterfly valve are shipped loose.
3. Standard motor voltages are 208-230-460/3/60. Totally enclosed and 50 cycle motors are optional.
4. Signal lights: Power On, Main Fuel, Ignition, and Flame Failure.

ORDERING INFORMATION (Specify)

1. Burner voltage, phase and cycle (See Note3)
2. Control Circuit Voltage (120/1/60)
3. Burner model and actual firing rate
4. Flame Safeguard Control
5. Special Code and/or Insurance Requirements
6. Available Gas Pressure

Type of fuel determines the model designation	
Model	Fuel
KG	Gas
KL	No. 2 Oil
KLG	No. 2 Oil / Gas

CAPACITIES AND SPECIFICATIONS	BURNER SIZE			
	13	17	21	25
GAS INPUT (Mbtu/hr)(See Note 1)	1,260	1,680	2,100	2,520
OIL INPUT (U.S.G.P.H.)(See Note 2)	9	12	15	18
BOILER HP @ 80% EFF.(See Note 3)	30	40	50	60
BLOWER MOTOR HP (See Note 5)	3/4	3/4	3/4	3/4
APPROX. SHIPPING WEIGHT (Lbs)	450	450	450	500

Notes:

1. Gas input based on natural gas at 1,000 Btu/cu.ft. and 0.60 gravity
2. Oil input based on NO. 2 oil at 140,000 Btu/gal.
3. Boiler overall efficiency of 80% estimated.
4. Gas pressure based on zero furnace pressure. For total pressure at manifold, add furnace pressure.
5. Impeller and motor HP is based on altitude up to 2,000 ft above sea level. For higher altitude or 50 Hz applications consult factory.

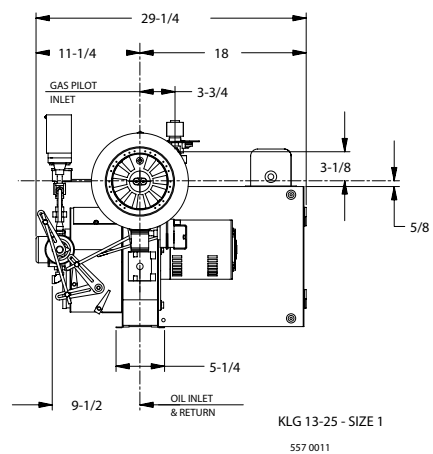
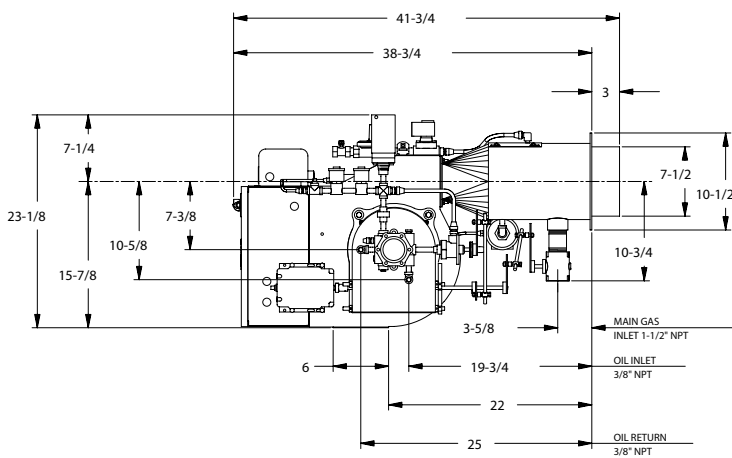
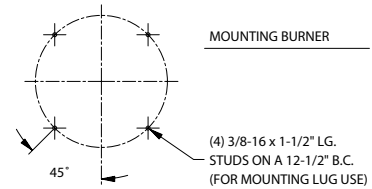
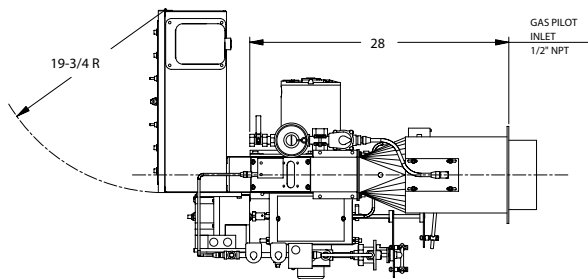

KLG 13-25 - SIZE 1
557 0011

