



Product Information

Model: LNDG, LNDLG, < 30 ppm
Burner Sizes: 42, 54, 63

GENERAL DESCRIPTION

The LND30/Series gas, oil, and combination gas/oil burner is a forced draft packaged burner system. A backward curved aluminum impeller mounted in a machined housing provides combustion air for various furnace pressures or high altitude applications. The air housing is hinged for convenient inspection or service of the firing head components.

Oil firing features a low pressure air atomizing design. A positive displacement oil metering unit, rotary vane air compressor, and air atomizing nozzle are integral parts of this system. The positive displacement oil metering unit is not affected by changes in oil temperature or viscosity.

Efficient gas combustion is attained by entering gas through ports ahead of the diffuser providing superior mixing of gas and air. Excellent flame retention is assured at all firing rates.

Combination gas/oil burners change from one fuel to the other by simply flipping a switch. No burner modifications or readjustment are required when changing from one fuel to the other.

Flue gas recirculation (FGR) is drawn through the burner blower assembly properly sized for the required NOx emission levels. An FGR control valve is positioned by the FGR system to provide FGR at all firing rates. An FGR shutoff valve is placed in the FGR line as part of a safety system. This shut-off valve prevents combustible gases from being drawn into the boiler furnace prior to pilot and main flame ignition. Proper operation of this system is proven by three (3) electrical safety interlocks. The system is equipped with ANSI flanges to allow easy installation into the FGR piping.

The LND30 Series is guaranteed to provide less than 30 ppm NOx, corrected at 3% O2 dry, and less than 50 ppm CO, throughout the firing range when firing natural gas.

Listed by Underwriters Laboratory. CSD-1, I.R.I., F.M., C.S.A. and other regulatory agency control options are available. Every burner is assembled, wired, and tested at the factory.

U.L. STANDARD EQUIPMENT

A. CONTROLS

1. 120/1/60 control circuit
2. Burner mounted control panel
3. Motor starter(s)
4. Panel signal lights (4) (See Note 4)
5. Full Modulation with manual potentiometer (135 ohm)
6. Fuel changeover switch (combination gas/oil models)
7. Flame safeguard controls (See Note 1)
8. Combustion air proving switch
9. High fire air interlock switch

B. OIL SYSTEM

1. Burner mounted oil metering system
2. Burner mounted integral atomizing air compressor
3. Air/lube oil reservoir
4. Fuel oil strainer (burner)
5. Oil solenoid valve
6. S.S.O. oil solenoid valve with relief valve
7. Atomizing air interlock switch

C. MAIN GAS SYSTEM (See Note 2)

1. Butterfly rate control valve
2. One motorized valve and solenoid valve (LND42-54)
3. One motorized valve with closure interlock and one solenoid valve motorized (LND63)
4. Gas shutoff cocks (2)
5. Main gas regulator
6. High and low gas pressure switches

D. GAS PILOT SYSTEM

1. Gas-electric interrupted pilot
2. Shutoff cock
3. Separate pilot regulator and valve

E. OTHER EQUIPMENT

1. 3450 rpm blower motor and aluminum impeller
2. Burner mounting flange
3. Refractory combustion cone and gasket
4. Hinged, swing-away air housing
5. Rotary air damper w/silencer
6. Bolt On Firing head
7. Cam trim U.L. listed

NOTES

1. U.V. scanner standard.
2. All main gas line valves and accessories upstream of butterfly valve are shipped loose.
3. Standard motor voltages are 208-230-460/3/60. Totally enclosed and 50 cycle motors are optional.
4. Signal lights: Power On, Main Fuel, Ignition, and Flame Failure.
5. A separate oil circulating pump set is required for all oil and combination fuel burners. The burner mounted unit is an oil input metering device only.

ORDERING INFORMATION (Specify)

1. Burner voltage, phase and cycle (See Note3)
2. Control Circuit Voltage (120/1/60)
3. Burner model and actual firing rate
4. Flame Safeguard Control
5. Special Code and/or Insurance Requirements
6. Available Gas Pressure

Type of fuel determines the model designation	
Model	Fuel
LNDG	Gas
LNDLG	No. 2 Oil / Gas

CAPACITIES AND SPECIFICATIONS	BURNER SIZE		
	42P	54P	63P
GAS INPUT (Mbtu/hr)(See Note 1)	3,360	4,200	5,250
OIL INPUT (U.S.G.P.H.)(See Note 2)	24	30	38
BOILER HP @ 80% EFF.(See Note 3)	80	100	125
GAS MANIFOLD PRESSURE (in.W.C.)(See Note 4)	6	9	14
BLOWER MOTOR HP (See Note 5)	3	5	5
OIL METERING UNIT MOTOR HP	-	-	-
AIR COMPRESSOR MOTOR HP	-	-	-
INTEGRAL AIR/OIL UNIT MOTOR HP	1	1	1
APPROX. SHIPPING WEIGHT (Lbs)	1,100	1,150	1,150
F.G.R. LINE PIPING SIZE (Inches)	6	6	6

Notes:

1. Gas input based on natural gas at 1,000 Btu/cu.ft. and 0.60 gravity.
2. Oil input based on NO. 2 oil at 140,000 Btu/gal.
3. Boiler overall efficiency of 80% estimated.
4. Gas pressure based on zero furnace pressure. For total pressure at manifold, add furnace pressure.
5. Impeller and motor HP is based on altitude up to 2,000 ft. above seal level.
For higher altitude or 50 Hz applications, consult factory.
Use model "S" up to 1.5" w.c. furnace pressure
Use model "P" up to 4" w.c. furnace pressure
Standard motor voltages are 208-230-460/3/60

Product Information

GENERAL DIMENSIONS

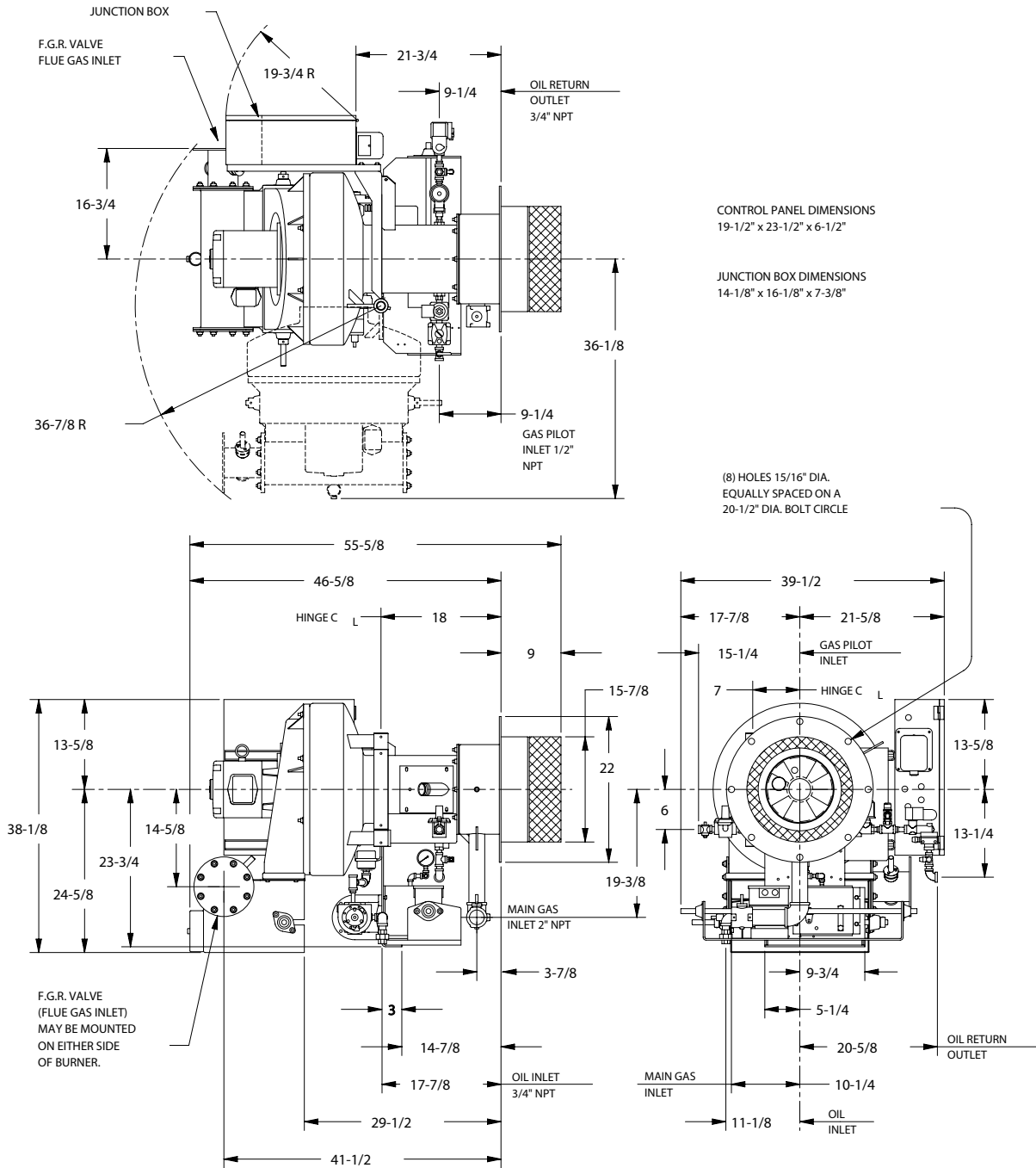

NOTE:
THESE DIMENSIONS ARE FOR REFERENCE ONLY. SPECIFICATIONS
AND DIMENSIONS ARE SUBJECT TO CHANGE WITHOUT NOTICE.

DIMENSION DIAGRAM
LNDLG-SERIES 42 THRU 63

551-0052-00

