



M/Series

PRODUCT INFORMATION

MODEL: MG, ME, MEG
BURNER SIZES: 34, 42, 54, 63

GENERAL DESCRIPTION

M/Series forced draft burners utilize an advanced air handling system, resulting in low blower motor horsepower, significantly lower noise levels and the ability to fire against higher furnace pressures. The heart of the air handling system is a perfectly balanced backward curved impeller. A five year guarantee on impellers is warranted against defects in material and factory workmanship.

MG gas burners burn gas under a controlled rate gas/air pressure mix. Gas is emitted from jets surrounding the air stream, producing a turbulent mixture which burns quietly and efficiently.

ME oil burners feature I.C.'s low pressure air atomizing design. A positive displacement oil metering unit, rotary vane remote air compressor, and air atomizing nozzle are integral parts of this system. Burner mounted, the positive displacement oil metering unit is not affected by changes in oil temperature or viscosity.

MODEL DESIGNATIONS	
MODEL	FUEL
MG	GAS
ME	No. 2-6 OIL with air atomizing
MEG	GAS/No. 2-6 OIL with air atomizing

MEG combination burners incorporate all the features of the MG, ME models. Alternate firing on either gas or oil can be obtained with just a flip of a switch. There is no need for burner modification or adjustment when changing from one fuel to another.

Listed by Underwriters Laboratory, CSD-1, I.R.I., FM, C.S.A., or other regulatory agency control options are available. Every IC burner is completely assembled, wired and tested at the factory. Main gas train components are shipped loose.

U.L. STANDARD EQUIPMENT

A. CONTROLS

1. 120/1/60 control circuit
2. Burner mounted controls
3. Motor starters
4. Panel signal lights (4) (See Note 4)
5. Full modulation with manual potentiometer
6. Fuel changeover switch (comb. gas/oil models)
7. Flame safeguard controls (See Note 1)
8. Combustion air interlock switch
9. Ignition transformer
10. High fire air interlock switch

B. OIL SYSTEM

1. Burner mounted oil metering unit
2. Separate air compressor module
3. Air/lube oil reservoir
4. Burner fuel oil strainer
5. 3-way oil solenoid valve
6. S.S.O. oil solenoid valve with relief valve
7. 3 KW nozzle line heater with cold oil lockout
8. High oil temp switch (loose)
9. Low oil pressure switch
10. Atomizing air interlock switch

C. MAIN GAS SYSTEM (See Note 2)

1. Butterfly rate control valve
2. One motorized valve and solenoid valve (M34, 42)
3. One motorized valve with closure interlock, and one solenoid valve (M54-63)
4. Gas shutoff cocks (2)
5. Main gas regulator
6. High and low pressure switches

D. PILOT SYSTEM

1. Gas-electric ignition
2. Pilot regulator and valve
3. Shutoff cock

E. OTHER EQUIPMENT

1. 3,450 RPM blower motor and impeller
2. Burner mounting flange
3. Refractory combustion cone and gasket
4. Hinged swing-away air housing
5. Bolt On firing head
6. Gas manifold is standard on all oil burners for future gas firing.
7. Cam Trim. U.L. listed (ME, MEG)

F. OPTIONAL EQUIPMENT

1. Control circuit transformer
2. Cam Trim. U.L. listed (MG)

NOTES

1. Lead sulfide scanner standard, U.V. and other controls optional, see IC-444. (U.V. not recommended for # 4-6 oil)
2. All main gas line valves and accessories up-stream of butterfly valve are shipped loose.
3. Totally enclosed and 50 cycle motors are optional.
4. Signal Lights: Power On, Main Fuel, Ignition and Flame Failure.
5. A separate oil circulation pump set is required for all oil and combination fuel burners. The burner-mounted unit is an input metering device only.

ORDERING INFORMATION (Specify)

1. Burner voltage, phase and cycle (See Note 3)
2. Control Circuit Voltage (120/1/60)
3. Burner Model and Actual Firing Rate.
4. Flame Safeguard Control.
5. Special Code and/or Insurance Requirements.
6. Available Gas Pressure.

CAPACITIES AND SPECIFICATIONS		BURNER SIZE			
		34	42	54	63
OIL INPUT (U.S.G.P.H.) (SEE NOTE 1)		25	31	40	45
GAS INPUT (M.BTU/HR.) (SEE NOTE 2)		3,500	4,200	5,600	6,300
BOILER HORSEPOWER @ 80% EFF. (SEE NOTE 3)		83	100	133	150
MAXIMUM STEAM CAPACITY @80% EFF. (LBS./HR.)(SEE NOTE 3)		2,863	3,450	4,588	5,175
METERING INTEGRAL OIL/AIR UNIT MOTOR HORSEPOWER		1/2	1/2	1/2	1/2
SEPARATE AIR COMPRESSOR MODULE		3	3	3	3
NOZZLE LINE HEATER (SAME VOLTAGE AS BLOWER MOTOR)		3KW	3KW	3KW	3KW
OIL PRESSURE P.S.I.G		15	15	15	15
STANDARD GAS TRAIN SIZE (INCHES)		1 1/2	2	2	2
GAS PRESSURE REQUIREMENTS AT REGULATOR INLET (INCHES W.C.) (SEE NOTE 4)		19.0	9.2	16.1	20.3
BLOWER MOTOR HORSEPOWER (SEE NOTE 5)	MODEL S:	2	2	2	3
	MODEL P:	2	2	3	3
RECOMMENDED COMBUSTION CHAMBER DIMENSIONS (INCHES)	LENGTH	55	56	60	65
	WIDTH	28	28	32	34
	HEIGHT	14	14	15	16
APPROX. SHIPPING WEIGHT (LBS.)		800	800	900	900

NOTES

- Oil input based on No. 2 oil @140,000 BTU/Gal.
- Gas input based on natural gas at 1000 BTU/cu. ft. and 0.60 specific gravity.
- Boiler overall efficiency of 80% estimated. Industrial Combustion does not guarantee overall boiler efficiency.
- Gas pressure based on zero furnace pressure. For total pressure required, add furnace pressure.
- Impeller and motor h.p. based on altitudes up to 2000 ft. above sea level. For impellers and motor sizes at higher altitudes, and 50 cycle applications, consult factory. Use Model "S" up to 0.75 W.C. furnace pressure. Use Model "P" up to 2.00" W.C. For higher furnace pressures, consult the factory. Standard motor voltages are 208-230-460/3/60.

GENERAL DIMENSIONS

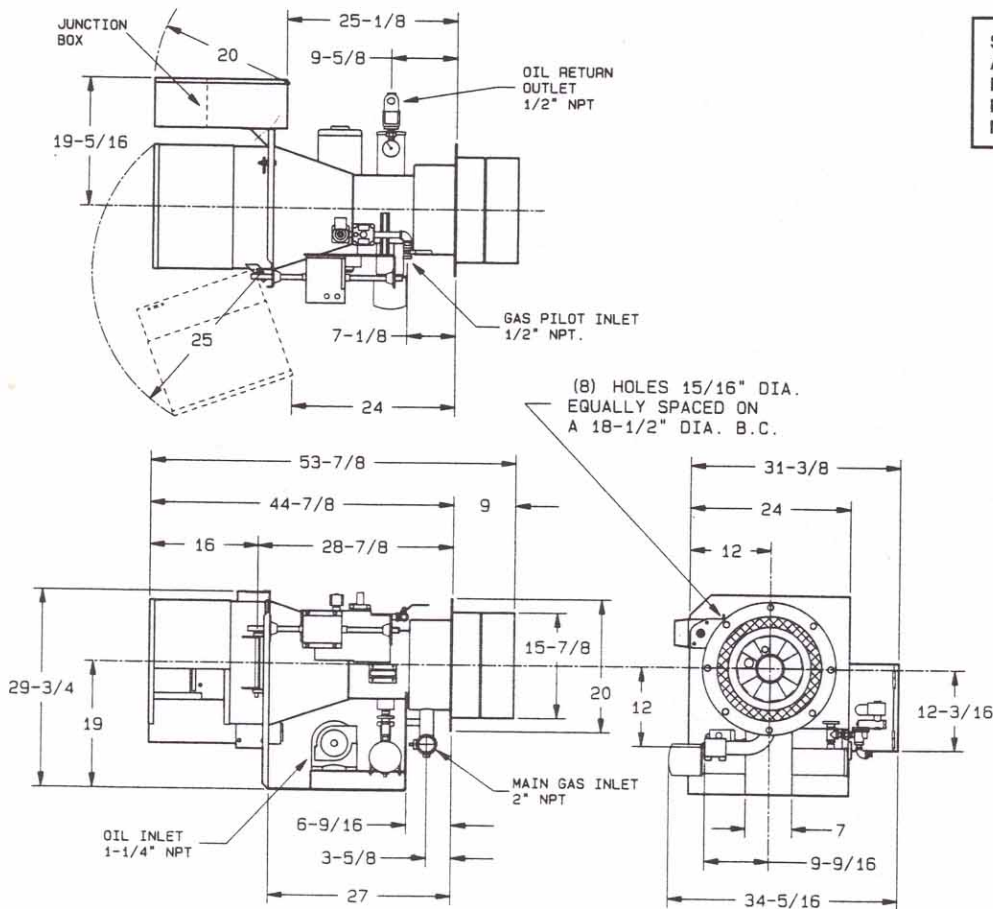

SPECIFICATIONS AND DIMENSIONS ARE SUBJECT TO CHANGE WITHOUT NOTICE. ALL DIMENSIONS ARE FOR REFERENCE ONLY. OPTIONAL EQUIPMENT MAY AFFECT DIMENSIONS.

CONTROL PANEL DIMENSIONS
23-1/2 x 19-1/2 x 7-1/4

JUNCTION BOX DIMENSIONS
14 x 12 x 6-1/2

SEPARATE COMPRESSOR DIMENSIONS

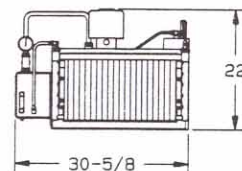
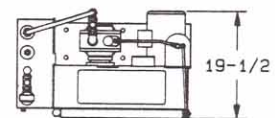

2-189