



Product Information

Model: MG, MM, MMG, ME, MEG

Burner Sizes: 14, 16, 19, 22, 25, 28, 30

GENERAL DESCRIPTION

The M-Series gas, oil, and combination gas/oil burner is a forced draft packaged burner system. A backward curved aluminum impeller mounted in a machined housing provides combustion air for various furnace pressures or high altitude applications. The air housing is hinged for convenient inspection or service of the firing head components.

Oil firing features low pressure air atomizing design. A positive displacement oil metering unit, rotary vane air compressor, and air atomizing nozzle are integral parts of this system. The positive displacement oil metering unit is not affected by changes in oil temperature or viscosity.

Efficient gas combustion is attained by entering gas through ports ahead of the diffuser providing superior mixing of gas

and air. Excellent flame retention is assured at all firing rates. A gas manifold is provided on all oil burners for future addition of gas.

Combination gas/oil burners change from one fuel to the other by simply flipping a switch. No burner modifications or readjustment are required when changing from one fuel to the other.

Listed by Underwriters Laboratory. CSD-1, I.R.I., F.M., C.S.A. and other regulatory agency control options are available. Every burner is assembled, wired, and tested at the factory. Compressor modules and main gas train components are shipped loose.

U.L. STANDARD EQUIPMENT

A. CONTROLS

1. 120/1/60 control circuit
2. Burner mounted control panel
3. Motor starter(s)
4. Panel signal lights (4) (See Note 4)
5. Full Modulation with manual potentiometer (135 ohm)
6. Fuel changeover switch (combination gas/oil models)
7. Flame safeguard controls (See Note 1)
8. Combustion air proving switch
9. High fire air interlock switch (M28-30)

B. OIL SYSTEM

1. Burner mounted air/oil metering system
2. Air/lube oil reservoir
3. Fuel oil strainer (burner)
4. 3-way oil solenoid valve
5. S.S.O. oil solenoid valve with relief valve
6. Atomizing air interlock switch
7. Nozzle line heater w/cold oil lockout

C. MAIN GAS SYSTEM (See Note 2)

1. Butterfly rate control valve
2. One motorized valve and solenoid valve
3. Gas shutoff cocks(2)
4. Main gas regulator
5. High and low gas pressure switches (M28-30)

D. GAS PILOT SYSTEM

1. Direct spark ignition (MM14-30)
2. Gas-electric interrupted pilot (MG-MMG-ME-MEG)
3. Shutoff cock
4. Separate pilot regulator and valve

E. OTHER EQUIPMENT

1. 3450 rpm blower motor and aluminum impeller
2. Burner mounting flange
3. Refractory combustion cone and gasket
4. Hinged, swing-away air housing
5. Gas manifold is standard on all oil burners for future gas firing

F. OPTIONAL EQUIPMENT

1. Cam trim UL listed
2. Control circuit transformer

NOTES

1. Lead sulphide scanner standard. U.V. optional.
2. All main gas line valves and accessories upstream of butterfly valve are shipped loose.
3. Standard motor voltages are 208-230-460/3/60. Totally enclosed and 50 cycle motors are optional.
4. Signal lights:
Power On, Main Fuel, Ignition, and Flame Failure.
5. A separate oil circulating pump set is required for all oil and combination fuel burners. The burner mounted unit is an oil input metering device only.

ORDERING INFORMATION (Specify)

1. Burner voltage, phase and cycle (See Note3)
2. Control Circuit Voltage (120/1/60)
3. Burner model and actual firing rate
4. Flame Safeguard Control
5. Special Code and/or Insurance Requirements
6. Available Gas Pressure

Type of fuel determines the model designation	
Model	Fuel
MG	Gas
MM	No. 2-5 Oil
MMG	No. 2-5 Oil / Gas
ME	No. 2-6 Oil
MEG	No. 2-6 Oil / Gas

CAPACITIES AND SPECIFICATIONS	BURNER SIZE			
	14	16	19	22
GAS INPUT (Mbtu/hr)(See Note 1)	1,400	1,680	1,960	2200
OIL INPUT (U.S.G.P.H.)(See Note 2)	10	12	14	15.7
BOILER HP @ 80% EFF.(See Note 3)	33	40	47	52
GAS MANIFOLD PRESSURE (in.W.C.)(See Note 4)	2	2.5	3	3
BLOWER MOTOR HP (See Note 5)	1/2	1/2	1/2	1/2
OIL METERING UNIT MOTOR HP (ME-MEG)	1/2	1/2	1/2	1/2
AIR COMPRESSOR MOTOR HP (ME-MEG)	3	3	3	3
INTEGRAL AIR/OIL UNIT MOTOR HP (MM-MMG)	3/4	3/4	3/4	3/4
NOZZLE LINE HEATER (KW)(MM-MMG-ME-MEG)	3	3	3	3
APPROX. SHIPPING WEIGHT (Lbs)	450	450	450	450

CAPACITIES AND SPECIFICATIONS	BURNER SIZE		
	25	28	30
GAS INPUT (Mbtu/hr)(See Note 1)	2,490	2,800	3,150
OIL INPUT (U.S.G.P.H.)(See Note 2)	18	20	22.5
BOILER HP @ 80% EFF.(See Note 3)	59	67	75
GAS MANIFOLD PRESSURE (in.W.C.)(See Note 4)	3	3	3.5
BLOWER MOTOR HP (See Note 5)	2	2	2
OIL METERING UNIT MOTOR HP (ME-MEG)	1/2	1/2	1/2
AIR COMPRESSOR MOTOR HP (ME-MEG)	3	3	3
INTEGRAL AIR/OIL UNIT MOTOR HP (MM-MMG)	3/4	3/4	3/4
NOZZLE LINE HEATER (KW)(MM-MMG-ME-MEG)	3	3	3
APPROX. SHIPPING WEIGHT (Lbs)	500	500	500

Notes:

1. Gas input based on natural gas at 1,000 Btu/cu.ft. and 0.60 gravity.
2. Oil input based on NO. 2 oil at 140,000 Btu/gal.
3. Boiler overall efficiency of 80% estimated.
4. Gas pressure based on zero furnace pressure. For total pressure at manifold, add furnace pressure.
5. Impeller and motor HP is based on altitude up to 2,000 ft. above seal level, and up to 1.5" WC furnace pressure.
For higher altitude or 50 Hz applications, consult factory.
Standard motor voltages are 208-230-460/3/60

GENERAL DIMENSIONS

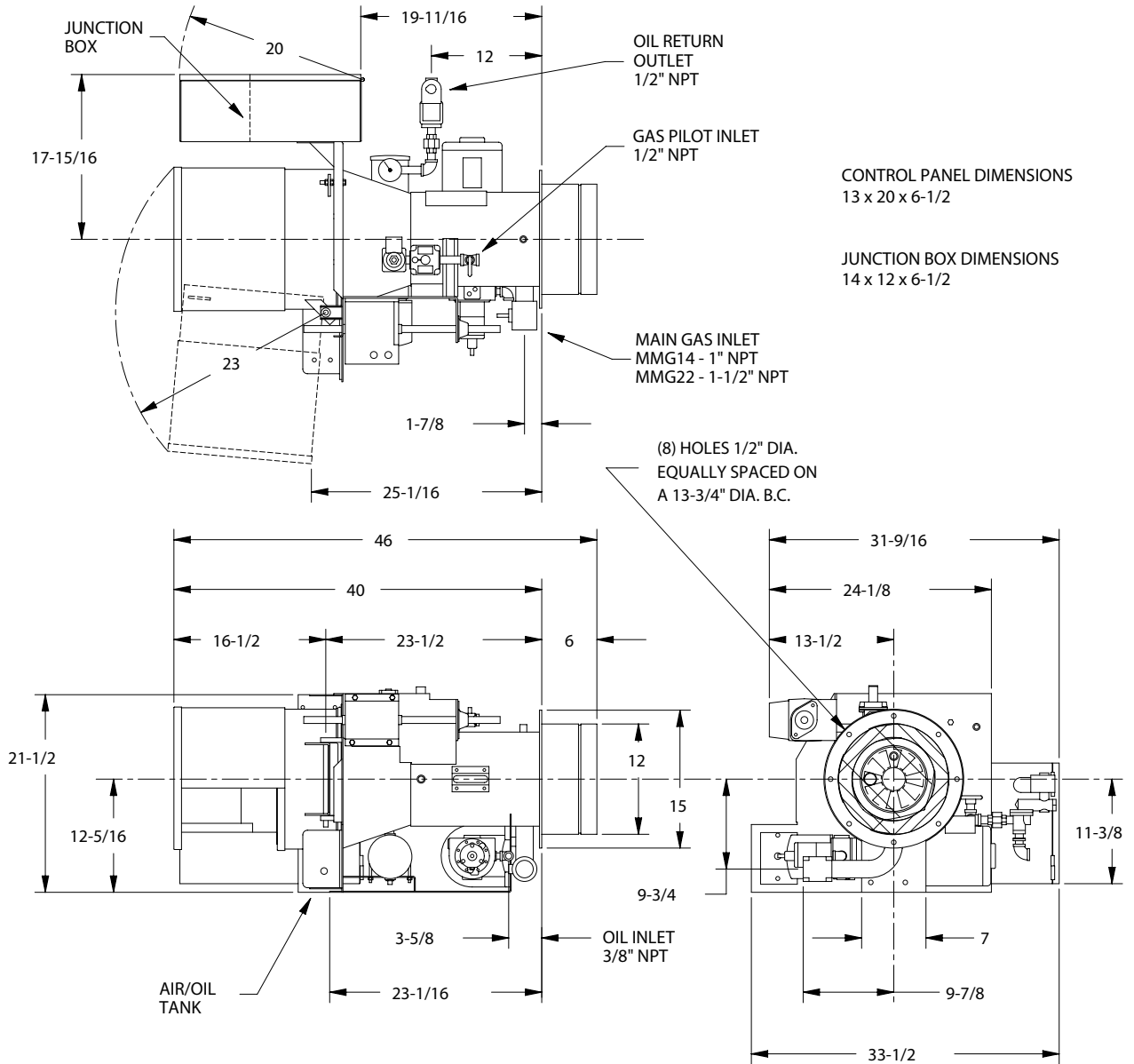

NOTE:
 THESE DIMENSIONS ARE FOR REFERENCE ONLY.
 SPECIFICATIONS AND DIMENSIONS ARE SUBJECT TO CHANGE WITHOUT NOTICE.
 BEFORE INSTALLATION, OBTAIN A CERTIFIED PRINT FROM THE FACTORY.

MODEL MMG 14-22
 DRWG h0-06379-01



GENERAL DIMENSIONS

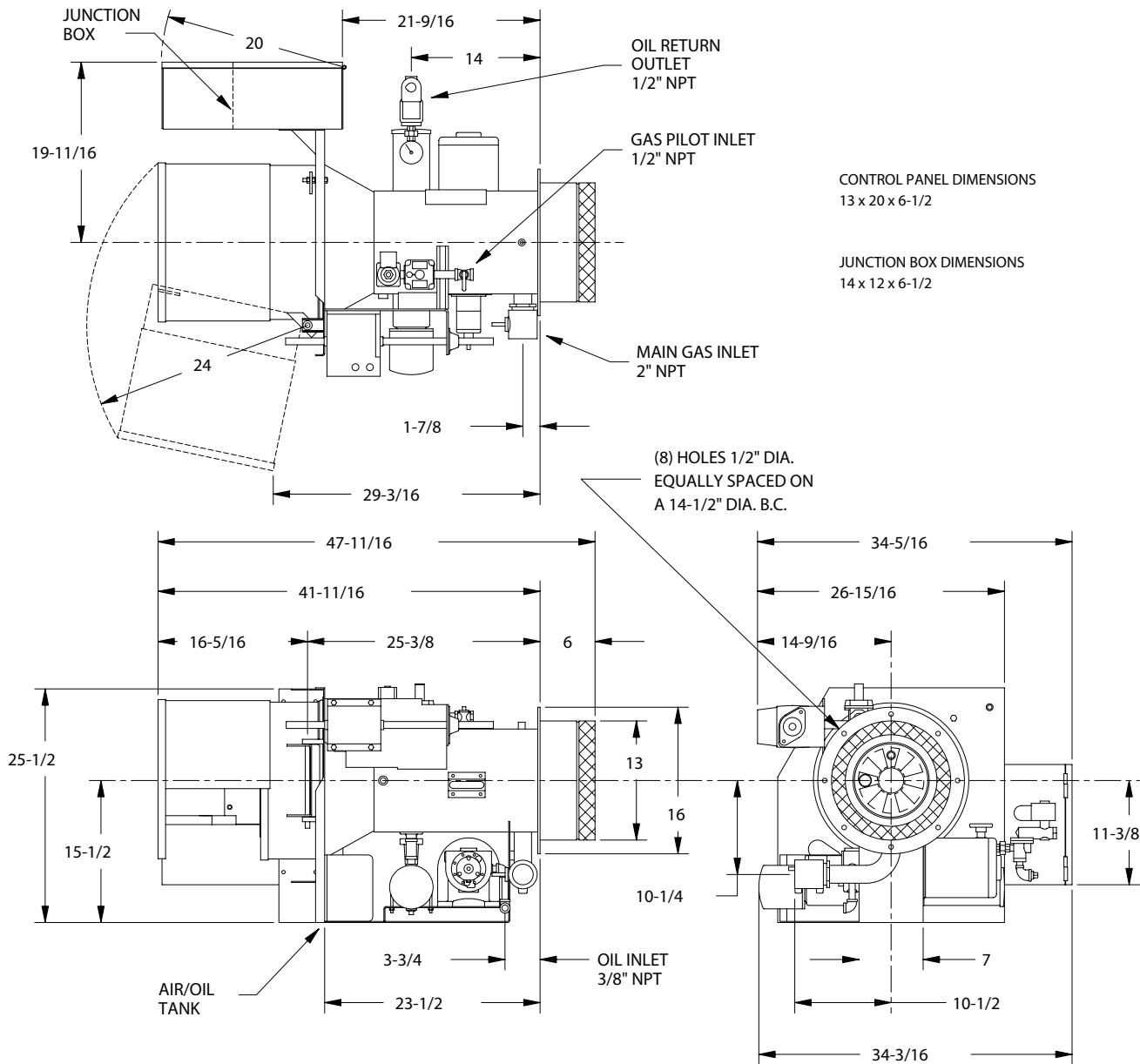

NOTE:
THESE DIMENSIONS ARE FOR REFERENCE ONLY. SPECIFICATIONS
AND DIMENSIONS ARE SUBJECT TO CHANGE WITHOUT NOTICE.

MODEL MMG 25-30
DRWG 552-00030-00