

**Typical Specifications For DynaFlame®
Domestic Hot Water Supply – Condensing
Copper & Copper Nickel Primary Heat Exchanger,
Stainless Steel Secondary Heat Exchanger
Models DF(N,P)W 0502– 6024**

The domestic hot water boiler shall be a CAMUS® DYNAFLAME® model _____ having an input rating of _____ Btu (kW) /hr. and _____ Btu (kW)/hr output for hydronic heating.

The domestic hot water boiler shall be design certified by CSA International and shall meet the requirements of ANSI Z21.10, and CSA 4.3. The domestic hot water boiler shall be vented as a Category II or IV condensing appliance.

Performance Overview:

- Boiler shall operate up to 95% thermal efficiency
- Heat exchanger shall be cylindrical 16 tube (Models 502 – 1202), 28 tube (Models 1502 – 4002), 32 tube (Models 4502 – 5002), 40 tube (Models 4524 – 6024) C12200 copper alloy with cast bronze headers and all gasket-less sealed design, optional C70600 cupronickel alloy is available
- Fine tuned combustion premix providing homogeneous air and gas combustion mix to a radial burner incorporating a knitted stainless steel wrap ensuring stable light off and efficient clean combustion.
- 5:1 gas input turn down ratio with sustained efficient combustion characteristics throughout entire modulating range
- Oxides of Nitrogen (NOx) of 9 ppm corrected to 3% oxygen.
- Category II and Category IV venting certification.
- The boiler is fully factory fire tested to obtain optimum combustion characteristics and to establish certified gas input rates.
- System safety and operating devices and controls are fully configured, calibrated and factory tested.
- Models consist of an input range of 500 MBTUH to 6000 MBTUH
- The boiler shall comply with the energy efficiency requirements of the latest edition of the ASHRAE 90.1 Standard

Combustion Chamber:

The combustion chamber shall be constructed of stainless steel, sealed water tight, chamber to be covered with minimal ¼" thick ceramic insulation. A stainless steel access door shall be provided for ease of service and inspection to the outer heat exchanger surface and an easily removable radial fired knitted fiber stainless steel burner to access the internal combustion chamber for inspection, service, and cleaning. A window view port shall be provided for visual inspection of the boiler combustion during firing.

Primary Heat Exchanger:

The heat exchanger shall be tested and inspected to A.S.M.E. Section IV requirements. The A.S.M.E. Section IV seal of approval will not be provided as standard for jurisdictions not requiring the A.S.M.E Section IV seal of approval. The heat exchanger shall be a four pass design with a maximum working pressure of 160psig (1100kPa) and maximum allowed operating temperature of 250°F (121°C). The heat exchanger is of cylindrical design, with integral copper finned tubes ¾" I.D., 0.064" minimum wall thickness, 7 fins per inch, with nominal fin height of ⅜". Each end of the tubes shall be expanded by mechanical rolling process into the headers. The heat exchanger shall be gasket-less. All header castings shall be bronze. The heat exchanger tubes shall be copper alloy C12200 with optional cupronickel alloy C70600 available.

Secondary Heat Exchanger:

The secondary heat exchanger shall be tested and tested and inspected to A.S.M.E. Section VIII requirements. The heat exchanger shall be a four pass design with a maximum working pressure of 160 psig (1100kPa) and maximum allowed working temperature of 210°F (98.8°C). The heat exchanger is a slab design with stainless diamond tubes welded into the headers. The heat exchanger is gasketless. The heat exchangers tube shall be stainless alloy TP316L.

Gas Train:

The gas train shall consist of a pressure regulating electro-hydraulic proportional air/gas main gas actuator providing a slow opening, fast closing shutoff valve and proportional 1:1 air/gas ratio control, a fast closing safety shutoff gas solenoid, and a low gas pressure switch. Optional high gas pressure switch is available. A factory pre-set combination metering valve and orifice shall be provided for setting combustion parameters. Models DF 502 – DF 6024 operate with a 5:1 turndown ratio.

Burner/Combustion:

The combustion air fan draws gas under negative pressure and mixes it with air to generate a fine tuned air gas mixture which is delivered under positive pressure to the radial knitted stainless steel burner. Combustion modulation is established by a variable frequency drive on all models. The burner shall be a 100% stainless steel vertical mounted radial fired type with stainless knitted metal fiber construction. The burner shall combust a precise amount of premixed combustion air and gas to provide equal distribution of heat for heat transfer throughout the entire heat exchanger. Combustion products are exhausted under minimum back pressure. Combustion operates with a 5:1 turn down ratio while sustaining combustion characteristics throughout the entire modulating range. Operation of up to 95% thermal efficiency and shall be certified for Oxides of Nitrogen (NOx) of 9 ppm corrected to 3% oxygen.

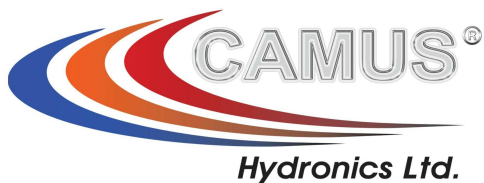

**Typical Specifications For DynaFlame®
Domestic Hot Water Supply – Condensing
Copper & Copper Nickel Primary Heat Exchanger,
Stainless Steel Secondary Heat Exchanger
Models DF(N,P)W 0502– 6024**

Firing Mode:

The burner combustion shall operate as proportional modulating with a 5:1 turndown ratio with a minimum 20% firing rate. Multiple boiler parallel sequential firing algorithms are proportional modulation. Light off shall be at no more than 50% input to assure rattle free soft start. Combustion shall be optionally suitable for natural gas, propane and dual fuels operation

Controls:

Standard controls include a SOLA electronic proportional integrated combination ignition limit/operator control accurate to 1°F (0.5°C) having a 4-20 mA output signal suitable for control of a variable frequency motor drive for modulating fan speeds. Controls are lead lag "Cascade" ready for control of up to eight boilers c/w Indoor outdoor reset. Control shall be equipped and ready with 4-20 mA or 0-10Vdc input for remote set point or modulating control. Control is BMS Modbus RTU protocol ready and capable of other alternate protocol conversions with additional optional gateway protocol converter. Control shall be supplied with a 7" mounted touch screen display which shall also provide for control system configuration and set up, readouts of boiler target, differential and inlet/outlet temperatures as well as accumulated runtime, enunciator diagnostics, real time data logging and firing rates. The complete control package shall be mounted on the front panel with a hinged door for easy access to all control modules. The boiler safety control string shall be furnished with controls for low gas pressure, fan air proving, blocked flue, high limit and flow switch. High gas pressure switch is standard on CSD1 equipped boilers and is standard on models 3000 and up. A flow switch and relief valve shall be provided for each unit. Additional control safeties shall include flame rectification, fan speed, and auto recycling high limit.

Ignition Module:

The ignition module shall employ a direct igniter with 3 tries for ignition followed by a 90 minute standby and repeat of 3 tries for ignition for models DF 502 - DF 2502. A proven pilot is used on models DF 3002 – DF 6024. Trial for ignition shall proceed with 15 seconds between retries. Ignition control shall include times for pre-purge, pre-ignition, ignition, and post purge.

Venting Options:

The following venting options shall be utilized:

- Category II Venting – single or combined vent
- Category IV Outside Air (Horizontal & Vertical)
- Category IV Through-wall Venting (Horizontal & Vertical)
- Outdoor Venting
- Category II & IV Direct Venting

The following Category II vent material shall be utilized:

- Stainless or AL29-4C material, single or double wall

The following Category IV vent material shall be utilized:

- Stainless or AL29-4C material, single or double wall, positive pressure rated

External Jacket and Fasteners:

The external jacket shall be of 430 stainless steel mirror finish panels and a powder paint coated access top cover assembled utilizing interference fit locks and minimal non-strip self tap screws for ease of removal and access to the heat exchanger and combustion air / gas control.



**Typical Specifications For DynaFlame®
Domestic Hot Water Supply – Condensing
Copper & Copper Nickel Primary Heat Exchanger,
Stainless Steel Secondary Heat Exchanger
Models DF(N,P)W 0502– 6024**

Engineer: _____ Job Location: _____ Date: _____

Prepared by: _____ Buyer's Name: _____ Quote #: _____
Job Name: _____ Buyer's Address: _____

**Input & Output
(MBTUH)**

Model	Condensing	
	Input	Output
0502	500	475
0752	750	713
1102	1100	1045
1202	1200	1140
1502	1500	1425
1752	1750	1663
2002	2000	1900
2502	2500	2375
3002	3000	2850
3502	3500	3325
4002	4000	3800
4502	4500	4275
5002	4999	4749
4524	4500	4275
5024	4999	4749
6024	6000	5700

DYNAFLAME® 0502 – 1202

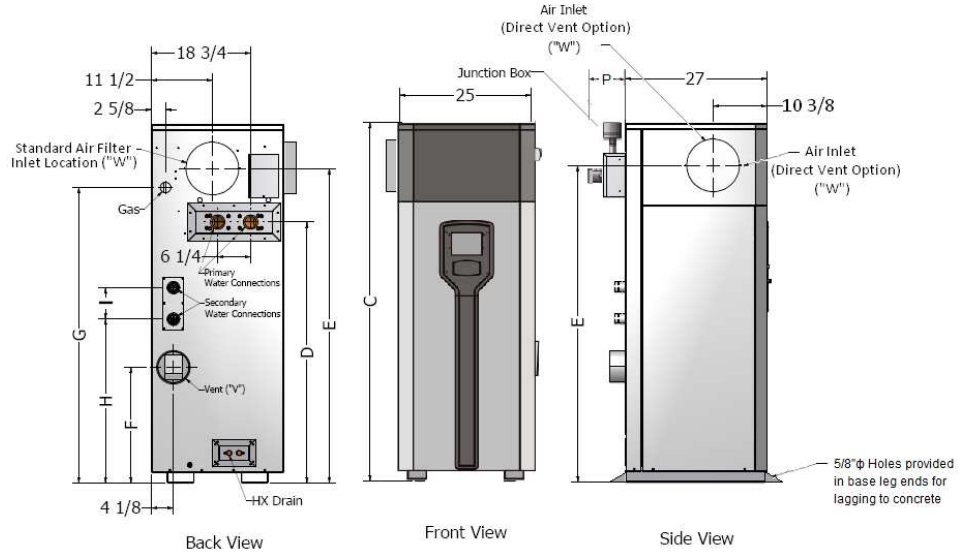

Shipping Weight

Model	Condensing
0502	593
0752	678
1102	704
1202	770
1502	899
1752	963
2002	999
2502	1085
3002	1120
3502	1330
4002	1380
4502	1500
5002	1720
4524	1610
5024	1815
6024	2210

DYNAFLAME® 1502 – 5002

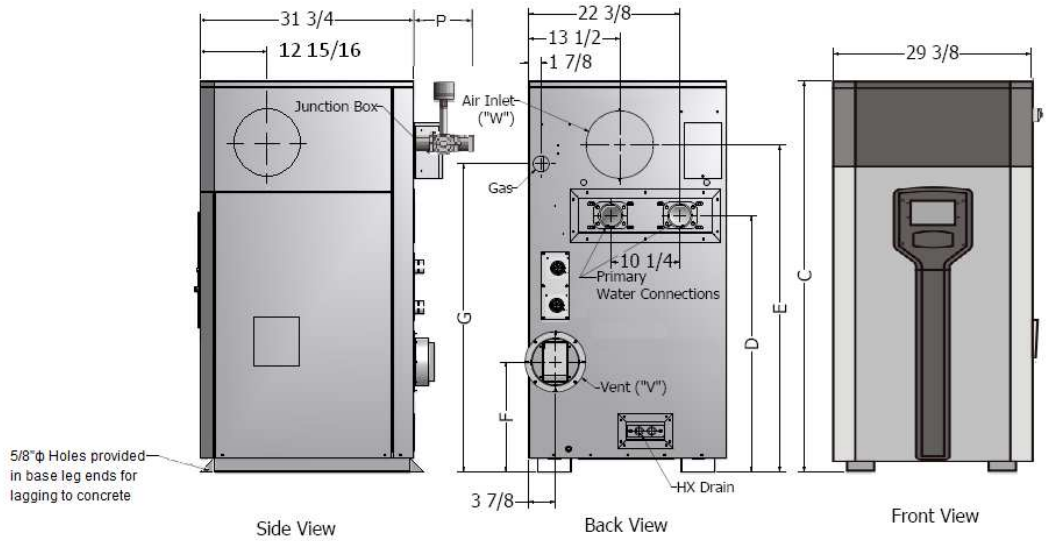

Secondary Heat Exchanger Water Connections

Model	Water Conn. Second. (Grooved)
502	1 1/2
752	1 1/2
1102	1 1/2
1202	1 1/2
1502	1 1/2
1752	1 1/2
2002	1 1/2
2502	1 1/2
3002	1 1/2
3502	1 1/2
4002	1 1/2
4502	1 1/2
5002	1 1/2
4524	1 1/2
5024	1 1/2
6024	1 1/2

DYNAFLAME® MEGA 4524– 6024

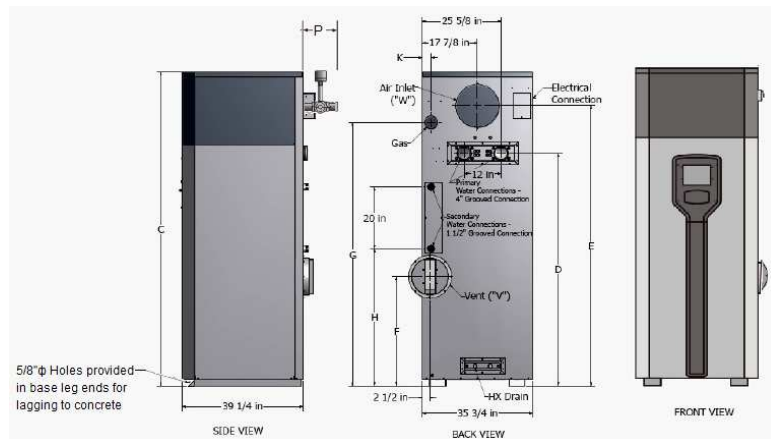



Typical Specifications For DynaFlame®
Domestic Hot Water Supply – Condensing
Copper & Copper Nickel Primary Heat Exchanger,
Stainless Steel Secondary Heat Exchanger
Models DF(N,P)W 0502– 6024

Dimensions [in.]

Model	Height Dim. "C"	Water Conn. "D"	Air Inlet "E"	Flue Height "F"	Gas Height "G"	Dim. "I"	Air Inlet Dia. "W"	Water Prim. [NPT, T.P.] [†]	Gas Conn. [NPT]	"K"
0502	45 5/8	27	37 1/4	13 1/4	33 5/8	6	6	2	1	2 5/8
0752	55	36 3/8	46 5/8	15 3/4	43	6	8	2	1	2 5/8
1102	68 1/4	49 5/8	59 7/8	22	56 1/4	6	8	2	1	2 5/8
1202	68 1/4	49 5/8	59 7/8	22	56 1/4	6	8	2	1	2 5/8
1502	58 1/8	38 1/4	48 5/8	16 3/8	45 7/8	6	10	2 1/2	1 1/4	1 7/8
1752	62 5/8	42 5/8	53 1/8	16 3/8	50 3/8	6	10	2 1/2	1 1/4	1 7/8
2002	66 7/8	46 7/8	57 3/8	20	53 5/8	6	12	3	1 1/4	1 7/8
2502	73 1/2	52 5/8	63 5/8	25 3/4	60 3/8	6	12	3	1 1/2	1 7/8
3002	79 1/2	58 5/8	69 5/8	31 3/4	66 3/8	6	12	3	1 1/2	1 7/8
3502	86 1/2	63 5/8	76	24 7/8	72 5/8	20	14	4	2	1 7/8
4002	91 1/2	68 5/8	81	29 7/8	77 5/8	20	14	4	2	1 7/8
4502	96 1/2	73 5/8	86	34 7/8	82 5/8	20	14	4	2 1/2	1 7/8
5002	101 1/2	78 5/8	91	39 7/8	87 5/8	20	14	4	2 1/2	1 7/8
4524	83	59 3/4	72 1/4	20 3/4	67 7/8	20	14	4 (Grooved)	2 1/2	3 1/2
5024	88 1/4	65	77 1/2	26	72 1/4	20	14	4 (Grooved)	2 1/2	3 1/2
6024	102	75 1/2	91	35 1/2	85 1/2	20	14	4 (Grooved)	3	2 3/4

[†]500-1200 Appliance Heat Exchanger Inlet/Outlet Connections are 2" NPT.
 1500-5000 Appliance Heat Exchanger Inlet/Outlet Connections are 3" NPT

T.P.: Terminal Point

Recovery Capacity

Model	100°F Rise	56°C Rise	80°F Rise	44°C Rise	60°F Rise	33°C Rise
	GPH	LPH	GPH	LPH	GPH	LPH
0502	569	2154	712	2693	949	3591
0752	854	3232	1067	4040	1423	5386
1102	1252	4740	1565	5925	2087	7900
1202	1366	5171	1708	6463	2277	8618
1502	1708	6463	2135	8079	2846	10772
1752	1992	7541	2490	9426	3320	12568
2002	2277	8618	2846	10772	3795	14363
2502	2846	10772	3558	13465	4743	17954
3002	3415	12927	4269	16158	5692	21544
3502	3984	15081	4981	18851	6641	25135
4002	4554	17236	5692	21544	7589	28726
4502	5123	19390	6404	24237	8538	32317
5002	5692	21544	7115	26931	9487	35907
4524	5123	19392	6404	24240	8539	32320
5024	5692	21545	7115	26931	9487	35908
6024	6791	25703	8489	32129	11318	42839

Primary Heat Exchanger Head Loss & Flow

Model	Temperature Rise Across Heat Exchanger			
	30°F*		35°F*	
	USGPM	ΔP-Ft.	USGPM	ΔP-Ft.
0502	28.0	0.7	24.0	0.5
0752	42.0	1.4	36.0	1.0
1102	61.6	2.7	52.8	2.1
1202	68.0	2.9	58.3	2.2
1502	83.9	1.9	71.9	1.4
1752	97.9	2.9	83.9	2.2
2002	111.9	4.1	95.9	3.1
2502	139.9	6.1	119.9	4.6
3002	167.9	8.4	143.9	7.0
3502	198.1	12.7	169.8	9.5
4002	226.9	17.0	194.5	12.7
4502	254.7	21.9	218.3	16.4
5002	282.9	27.6	242.5	20.7
4524	254.7	15.3	218.3	11.4
5024	282.9	19.6	242.5	14.9
6024	339.5	31.8	291.0	24.1

* Rise across main heat exchanger only

Sec. Heat Exchanger Head Loss & Flow

Model	USGPM	ΔP-Ft.
502	10.0	0.4
752	13.0	0.7
1102	22.0	1.8
1202	24.0	2.1
1502	30.0	3.1
1752	35.0	4.2
2002	40.0	5.5
2502	50.0	8.0
3002	60.0	11.5
3502	40.0*	8.5
4002	46.0*	11.0
4502	52.0*	14.0
5002	57.0*	16.5
4524	52.0*	14.0
5024	57.0*	16.5
6024	68.0*	25.0

*Flow for 15°F rise at high fire

Condensing Venting

Model	Vent ("V") Diameter Inches			
	Outdoor	Cat. IV Up to 50 ft	Cat. IV Up to 100 ft	Cat. II
0502	4	4	6	5
0752	6	6	8	6
1102	6	6	8	7
1202	6	6	8	7
1502	7	7	10	8
1752	7	7	10	8
2002	8	8	12	9
2502	8	8	12	9
3002	8	8	12	10
3502	9	9	14	12
4002	9	9	14	12
4502	10	10	14	12
5002	10	10	14	12
4524	10	10	14	12
5024	10	10	14	12
6024	12	12	14	12

Current drawn by Boiler @115 Volts Single Phase 60 Hz

Model	Max Amps Draw - Boiler Only
0502	7
0752	7
1102	7
1202	7
1502	11
1752	11
2002	11
2502	14

Current drawn by Boiler @ 230 Volts 60 Hz

Model	Max Amps Draw - Boiler Only	Phase
3002	14	Single
3502	16	Single
4002	16	Single
4502	24	Single
5002	18	Three
4524	24	Single
5024	18	Three
6024	18	Three

Model # _____
 Total Input _____ BTU/hr
 Total Output _____ BTU/hr

Of Units _____ Type of Gas _____
 Flow _____ USGPM @ Allowable Pressure Drop _____ ft.
 Optional Accessories _____