

D SERIES

TECHNICAL DATA INFORMATION PACKET

**INDUSTRIAL
COMBUSTION**

Table of Contents

D Series

Uncontrolled Emissions DG, DL, DLG

Technical Data Sheet	3
Ratings Table.....	4
Dimension Table.....	5

D Series

Uncontrolled Emissions DM, DMG

Technical Data Sheet	6
Ratings Table.....	7
Dimension Table.....	8

D Series

Uncontrolled Emissions DE, DEG

Technical Data Sheet	9
Ratings Table.....	10
Dimension Table.....	11

D Series

<30 PPM Low NO_x LNDG, LNDLG

Technical Data Sheet	12
Ratings Table.....	13
Dimension Table.....	14-15

Technical Data

D Series

Choice of NFPA, CSD-1, GAP, and FM for U.S. or Canadian units

Uncontrolled Emissions Configuration (DG, DL, DLG)

4.2 - 42.0 MM BTU/H NG; 30 - 300 GPH #2 OIL

Standard equipment:	Combustion Control System options:	Fuel options:
3450 RPM motor, panel signal lights (Power On, Main Fuel, Ignition, Flame Failure), dry oven and gasket, combustion air proving switch, high fire air proving switch, 120/1/60 control circuit, burner mounted panel, hinged blast tube with right-hand swing. Gas and gas/oil units only: butterfly rate control valve, high/low gas pressure switches, two gas shutoff cocks, main gas regulator, shipped loose gas train.	Parallel Positioning Combustion Control System with O ₂ Trim and Variable Frequency Drive (VFD)	Main Fuel: Natural gas (DG), #2 oil - air atomized (DL) or Combination gas/ #2 oil - air atomized (DLG). Igniter Fuel: Natural gas and/or propane. Fuel Changeover Switch: Combination gas/oil units only (DLG).

Series Features

◊ Optional Feature

	D-42	D-54 to D-105	D-145	D-175 to D-210	D-252 to D-315	D-336 to D-420
Flame Safeguard						
UV Scanner	•	•	•	•	•	•
Mode of Operation						
Full Modulation Firing	•	•	•	•	•	•
Auto-Manual Firing Rate Control	• ¹	• ¹	• ¹	• ¹	• ¹	• ¹
Ignition						
Gas/Electric Pilot and Ignition Transformer	•	•	•	•	•	•
#2 Oil Pilot (DL, DLG)	◊	◊	◊	◊	◊	◊
Oil Components						
3-Way Solenoid Valve	•	•	•	•	•	•
2-Way Solenoid Valve	•	•	•	•	•	•
3-Way Motorized POC Valve	◊	◊	◊	◊	•	•
2-Way Motorized POC Valve	◊	◊	◊	◊	◊	◊
Atomizing Air Proving Switch	•	•	•	•	•	•
Low Oil Pressure Switch	◊	◊	◊	•	•	•
Burner Mounted Integral Oil/Air System	•	•	•			
Burner Mounted Oil Metering System				•	•	•
Separately Mounted Air Compressor Module				•	•	•
Gas Components						
Motorized Valve w/o POC & Solenoid Valve	•					
Motorized Valve w/ POC & Solenoid Valve	◊	•				
Motorized Valve w/ POC (2)	◊	◊	◊	◊	◊	◊
Motorized w/ POC & Motorized w/o POC	◊	◊	•	•	•	•
Normally Open Vent Valve	◊	◊	•	•	•	•

¹ Standard for full modulation; optional on select parallel positioning systems

Note: A separate oil circulating pump set is required for all DL and DLG burners. The burner mounted unit is an oil input metering device only.

Standard Ratings

D Series

DG - DL - DLG: Gas, #2 Oil, Gas/Oil Configuration

	Gas Input MBH	#2 Oil Input GPH	BHP @ 80% Eff.	Blower Motor HP "S" ¹	Blower Motor HP "P" ²	Integral Oil/Air System Motor HP 3 Phase	Separate Compressor Module Motor HP 3 Phase	Oil Metering System Motor HP 3 Phase	Standard Gas Train Pipe Size (in.)	Gas Pressure Required ("w.c.) ³	
Model No. & Frame Size											
D-42-1	4,200	30	100	3	3	1	-	-	2	9.2	208 / 230 / 460 / 3
D-54-1	5,400	39	129	3	5	1	-	-	2	15.3	
D-63-1	6,550	47	156	5	5	1	-	-	2	21.6	
D-84-2	8,400	60	200	5	7 1/2	1	-	-	2 1/2	18.0	
D-105-2	10,500	75	250	7 1/2	10	2	-	-	3	16.0	
D-145-3	15,000	107	357	15	15	2	-	-	3	2 PSI	
D-175-4	17,500	125	417	20	20	-	5	1/2	3	5 PSI	
D-210-5	21,000	150	500	20	25	-	5	3/4	3	5 PSI	230 / 460 / 3
D-252-6	25,200	180	600	25	30	-	7 1/2	3/4	3	5 PSI	
D-300-6	30,000	215	714	40	40	-	7 1/2	3/4	3	10 PSI	460 / 3
D-315-6	31,500	225	750	-	60	-	7 1/2	3/4	3	10 PSI	
D-336-7	33,600	240	800	-	60	-	7 1/2	3/4	3	10 PSI	
D-378-8	37,800	270	900	-	75	-	15	1	4	10 PSI	
D-420-8	42,000	300	1,000	-	75	-	15	1	4	10 PSI	

¹ Use model "S" up to 1.5" w.c. furnace pressure, consult the factory for higher pressures

² Use model "P" up to 4.0" w.c. furnace pressure, consult the factory for higher pressures

³ Standard gas pressures only, lower gas supply pressure configurations available for New York City requirements

Input is based on fuel BTU content, listed furnace pressure and altitude of 2,000 feet or less. If altitude > 2,000 feet and < 8,000 feet, derate capacity 4% per 1,000 feet over 2,000. Consult factory for higher altitudes. If furnace pressure exceeds listed value, derate capacity 5% for every 0.5" w.c. of pressure in excess of stated. Consult factory if derate exceeds 20%. Gas input is based on natural gas with 1,000 BTU/cu.ft. and 0.60 gravity. For total pressure at manifold, add furnace pressure. Oil input is based on 140,000 BTU/gal. Consult factory for 50 Hz. applications.

Standard Dimensions

D Series

DG - DL - DLG: Gas, #2 Oil, Gas/Oil Configuration

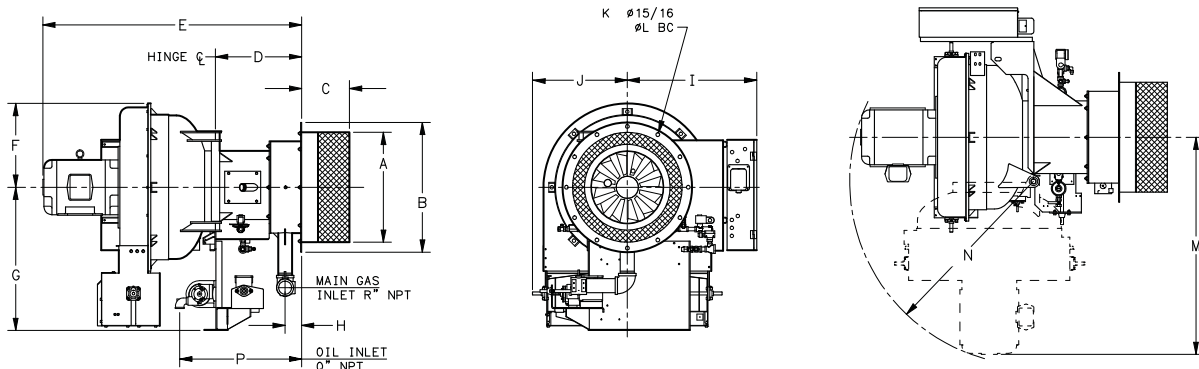

DIM	Burner Frame Size & Model Number										
	Size 1	Size 2		Size 3	Size 4	Size 5	Size 6		Size 7	Size 8	
	42-63	84	105	145	175	210	252-300	315	336	378-420	
Length in inches											
Overall length	E	45 3/4	44 5/8	45 5/8	56 7/8	60	64 3/4	66 3/8	69 3/8	68 1/2	73 7/8
Width in inches											
Center line to right side	I	21 5/8	23 7/8	23 7/8	24 3/4	25 1/4	32 3/8	32 3/8	32 3/8	32 3/8	36 7/8
Center line to left side	J	17 7/8	17 5/8	17 5/8	21	22	23 3/4	23 3/4	23 3/4	23 3/4	28
Height in inches											
Center line to top	F	13	15	15	15	15	21	21	21	21	23
Center line to bottom	G	23 3/4	25 3/8	25 3/8	30 1/8	31 7/8	35 7/8	37 3/8	37 3/8	38 7/8	39 7/8
Dry oven dimensions in inches											
Diameter of dry oven	A	15 7/8	19	19	22	27 1/2	27 1/2	31 1/2	31 1/2	34 5/8	34 5/8
Depth of dry oven	C	9	10	10	12	12	12	15	15	18	18
Mounting flange dimensions in inches											
Diameter	B	22	24	24	27	32 1/2	32 1/2	37	37	40	42
Flange to hinge	D	18	18	18	21 1/2	21 1/2	21 1/2	22	22	22	24
Diameter of bolt circle	L	20 1/2	22	22	25	30 1/2	30 1/2	35	35	38	40
Number of mounting holes	K	8	12	12	12	12	12	12	12	12	12
Hinge swing dimensions in inches											
Center line to outer hinge clearance	M	32 3/4	35 3/8	36 3/8	45	50 5/8	54 3/8	56 7/8	59 7/8	60 5/8	69 1/8
Hinge swing radius	N	27 3/8	29	30	37 3/8	41 1/4	46	47 1/2	50 1/4	50 1/4	55 5/8
Oil inlet dimensions in inches											
Diameter of oil inlet	Q	3/4	1 1/4	1 1/4	1 1/4	1 1/4	1 1/4	1 1/4	1 1/4	1 1/4	1 1/4
Mounting flange to oil inlet	P	17 7/8	27	27	30 1/2	30 1/2	30 1/2	31	31	30 7/5	33 3/4
Gas inlet dimensions in inches											
Diameter of gas inlet	R	2	2 1/2	2 1/2	3	3	3	4	4	4	4
Mounting flange to gas inlet	H	3 5/8	3 5/8	3 5/8	4 1/8	4 1/8	4 1/8	4 5/8	4 5/8	4 5/8	3 7/8

Accompanying dimensions, while sufficiently accurate for layout purposes, must be confirmed for construction.

Technical Data

D Series

Uncontrolled Emissions Configuration (DM, DMG)

4.2 - 42.0 MM BTU/H NG; 29 - 290 GPH #2-5 OIL

UL listed with choice of NFPA, CSD-1, GAP, and FM for U.S. or Canadian units

Standard equipment:	Combustion Control System options:	Fuel options:
3450 RPM motor, panel signal lights (Power On, Main Fuel, Ignition, Flame Failure), dry oven and gasket, combustion air proving switch, high fire air proving switch, 120/1/60 control circuit, burner mounted panel, hinged blast tube with right-hand swing. Gas and gas/oil units only: butterfly rate control valve, high/low gas pressure switches, two gas shutoff cocks, main gas regulator, shipped loose gas train.	Parallel Positioning Combustion Control System with O ₂ Trim and Variable Frequency Drive (VFD)	Main Fuel: #2-5 oil - Air atomized (DM) or Combination natural gas/ #2-5 oil - air atomized (DMG). Igniter Fuel: Natural gas and/or propane. Fuel Changeover Switch: Combination gas/oil units only (DMG).

Series Features

◊ Optional Feature

	D-42 to D-105	D-145	D-175	D-210	D-252 to D-315	D-336 to D-420
Flame Safeguard						
IR Scanner	•	•	•	•	•	•
Mode of Operation						
Full Modulation Firing	•	•	•	•	•	•
Auto-Manual Firing Rate Control	• ¹	• ¹	• ¹	• ¹	• ¹	• ¹
Ignition						
Gas/Electric Pilot and Ignition Transformer	•	•	•	•	•	•
#2 Oil Pilot	◊	◊	◊	◊	◊	◊
Oil Components						
3-Way Oil Solenoid Valve	•	•	•	•		
2-Way Oil Solenoid Valve	•	•	•	•	•	•
3-Way Motorized POC Valve	◊	◊	◊	◊	•	•
2-Way Motorized POC Valve	◊	◊	◊	◊	◊	◊
Atomizing Air Proving Switch	•	•	•	•	•	•
Low Oil Pressure Switch	◊	◊	•	•	•	•
Burner Mounted Integral Oil/Air System	•	•				
Burner Mounted Oil Metering System			•	•	•	•
Separately Mounted Air Compressor Module			•	•	•	•
Nozzle Line Heater with Cold Oil Lockout	•	•	•	•	•	•
Gas Components						
Motorized Valve w/o POC & Solenoid Valve	•					
Motorized Valve w/ POC & Solenoid Valve	◊	•				
Motorized Valve w/ POC (2)	◊	◊	◊	◊	◊	◊
Motorized w/ POC & Motorized w/o POC	◊	◊	•	•	•	•
Normally Open Vent Valve	◊	•	•	•	•	•

¹ Standard for full modulation; optional on select parallel positioning systems

Note: A separate oil circulating pump set is required for all DM and DMG burners. The burner mounted unit is an oil input metering device only.

Standard Ratings

D Series

DM - DMG: #2-5 Oil, Gas/Oil Configuration

	Gas Input MBH	#2-5 Oil Input GPH	BHP @ 80% Eff.	Blower Motor HP "S" ¹	Blower Motor HP "P" ²	Integral Oil/Air System Motor HP 3 Phase	Separate Compressor Module Motor HP 3 Phase	Oil Metering System Motor HP 3 Phase	Standard Gas Train Pipe Size (in.)	Gas Pressure Required ("w.c.) ³	Nozzle Line Heater (kw)	
Model No. & Frame Size												
D-42-1	4,200	29	100	3	3	1	-	-	2	9.2	3	208 / 230 / 460 / 3
D-54-1	5,400	38	129	3	5	1	-	-	2	15.3	3	
D-63-1	6,550	45	156	5	5	2	-	-	2	21.6	3	
D-84-2	8,400	58	200	5	7 1/2	2	-	-	2 1/2	18.0	5	
D-105-2	10,500	73	250	7 1/2	10	2	-	-	3	16.0	5	
D-145-3	15,000	104	357	15	15	2	-	-	3	2 PSI	5	
D-175-4	17,500	121	417	20	20	-	5	1/2	3	5 PSI	5	
D-210-5	21,000	145	500	20	25	-	5	3/4	3	5 PSI	7	230 / 460 / 3
D-252-6	25,200	174	600	25	30	-	7 1/2	3/4	3	5 PSI	10	
D-300-6	30,000	207	714	40	40	-	7 1/2	3/4	3	10 PSI	10	460 / 3
D-315-6	31,500	217	750	-	60	-	7 1/2	3/4	3	10 PSI	10	
D-336-7	33,600	232	800	-	60	-	7 1/2	3/4	3	10 PSI	10	
D-378-8	37,800	261	900	-	75	-	15	1	4	10 PSI	10	
D-420-8	42,000	290	1,000	-	75	-	15	1	4	10 PSI	10	

¹ Use model "S" up to 1.5" w.c. furnace pressure, consult the factory for higher pressures

² Use model "P" up to 4.0" w.c. furnace pressure, consult the factory for higher pressures

³ Standard gas pressures only, lower gas supply pressure configurations available for New York City requirements

Input is based on fuel BTU content, listed furnace pressure and altitude of 2,000 feet or less. If altitude > 2,000 feet and < 8,000 feet, derate capacity 4% per 1,000 feet over 2,000. Consult factory for higher altitudes. If furnace pressure exceeds listed value, derate capacity 5% for every 0.5" w.c. of pressure in excess of stated. Consult factory if derate exceeds 20%. Gas input is based on natural gas with 1,000 BTU/cu.ft. and 0.60 gravity. For total pressure at manifold, add furnace pressure. Oil input is based on 145,000 BTU/gal. Consult factory for 50 Hz. applications.

Standard Dimensions

D Series

DM - DMG: #2-5 Oil, Gas/Oil Configuration

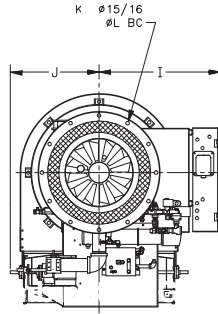
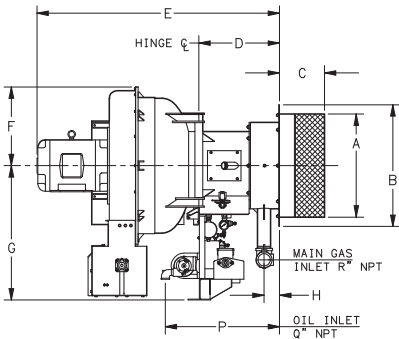

Models 42 - 145

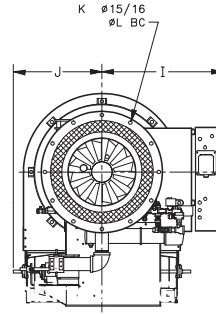

Models 175 - 420

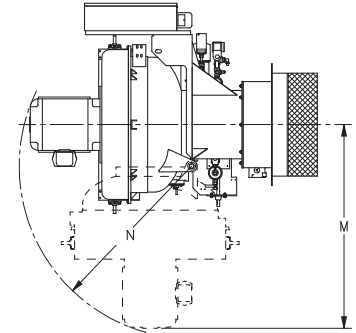

Burner Frame Size & Model Number

DIM	Burner Frame Size & Model Number										
	Size 1	Size 2		Size 3	Size 4	Size 5	Size 6		Size 7	Size 8	
	42-63	84	105	145	175	210	252-300	315	336	378-420	
Length in inches											
Overall length	E	45 3/4	44 5/8	45 5/8	56 7/8	60	64 3/4	66 3/8	69 3/8	68 1/2	73 7/8
Width in inches											
Center line to right side	I	21 5/8	23 7/8	23 7/8	24 3/4	25 1/4	32 3/8	32 3/8	32 3/8	32 3/8	36 7/8
Center line to left side	J	17 7/8	17 5/8	17 5/8	21	22	23 3/4	23 3/4	23 3/4	23 3/4	28
Height in inches											
Center line to top	F	13	15	15	15	15	21	21	21	21	23
Center line to bottom	G	23 3/4	25 3/8	25 3/8	30 1/8	31 7/8	35 7/8	37 3/8	37 3/8	38 7/8	39 7/8
Dry oven dimensions in inches											
Diameter of dry oven	A	15 7/8	19	19	22	27 1/2	27 1/2	31 1/2	31 1/2	34 5/8	34 5/8
Depth of dry oven	C	9	10	10	12	12	12	15	15	18	18
Mounting flange dimensions in inches											
Diameter	B	22	24	24	27	32 1/2	32 1/2	37	37	40	42
Flange to hinge	D	18	18	18	21 1/2	21 1/2	21 1/2	22	22	22	24
Diameter of bolt circle	L	20 1/2	22	22	25	30 1/2	30 1/2	35	35	38	40
Number of mounting holes	K	8	12	12	12	12	12	12	12	12	12
Hinge swing dimensions in inches											
Center line to outer hinge clearance	M	32 3/4	35 3/8	36 3/8	45	50 5/8	54 3/8	56 7/8	59 7/8	60 5/8	69 1/8
Hinge swing radius	N	27 3/8	29	30	37 3/8	41 1/4	46	47 1/2	50 1/4	50 1/4	55 5/8
Oil inlet dimensions in inches											
Diameter of oil inlet	Q	3/4	1 1/4	1 1/4	1 1/4	1 1/4	1 1/4	1 1/4	1 1/4	1 1/4	1 1/4
Mounting flange to oil inlet	P	17 7/8	27	27	30 1/2	30 1/2	30 1/2	31	31	30 7/8	33 3/4
Gas inlet dimensions in inches											
Diameter of gas inlet	R	2	2 1/2	2 1/2	3	3	3	4	4	4	4
Mounting flange to gas inlet	H	3 5/8	3 5/8	3 5/8	4 1/8	4 1/8	4 1/8	4 5/8	4 5/8	4 5/8	3 7/8

Accompanying dimensions, while sufficiently accurate for layout purposes, must be confirmed for construction.

Technical Data

D Series

Uncontrolled Emissions Configuration (DE, DEG)

4.2 - 42.0 MM BTU/H NG; 28 - 280 GPH #2-6 OIL

UL listed with choice of NFPA, CSD-1, GAP, and FM for U.S. or Canadian units

Standard equipment:	Combustion Control System options:	Fuel options:
3450 RPM motor, panel signal lights (Power On, Main Fuel, Ignition, Flame Failure), dry oven and gasket, combustion air proving switch, high fire air proving switch, 120/1/60 control circuit, burner mounted panel, hinged blast tube with right-hand swing. Gas and gas/oil units only: butterfly rate control valve, high/low gas pressure switches, two gas shutoff cocks, main gas regulator, shipped loose gas train.	Parallel Positioning Combustion Control System with O ₂ Trim and Variable Frequency Drive (VFD)	Main Fuel: #2-5 oil - Air atomized (DM) or Combination natural gas/ #2-5 oil - air atomized (DMG). Igniter Fuel: Natural gas and/or propane. Fuel Changeover Switch: Combination gas/oil units only (DMG).

Series Features

◊ Optional Feature

	D-42 to D-105	D-145	D-175	D-210	D-252 to D-315	D-336 to D-420
Flame Safeguard						
IR Scanner	•	•	•	•	•	•
Mode of Operation						
Full Modulation Firing	•	•	•	•	•	•
Auto-Manual Firing Rate Control	• ¹	• ¹	• ¹	• ¹	• ¹	• ¹
Ignition						
Gas/Electric Pilot and Ignition Transformer	•	•	•	•	•	•
#2 Oil Pilot	◊	◊	◊	◊	◊	◊
Oil Components						
3-Way Oil Solenoid Valve	•	•	•	•		
2-Way Oil Solenoid Valve	•	•	•	•	•	•
3-Way Motorized POC Valve	◊	◊	◊	◊	•	•
2-Way Motorized POC Valve	◊	◊	◊	◊	◊	◊
Atomizing Air Proving Switch	•	•	•	•	•	•
Low Oil Pressure Switch	•	•	•	•	•	•
Burner Mounted Oil Metering System	•	•	•	•	•	•
Separately Mounted Air Compressor Module	•	•	•	•	•	•
Nozzle Line Heater with Cold Oil Lockout	•	•	•	•	•	•
Gas Components						
Motorized Valve w/o POC & Solenoid Valve	•					
Motorized Valve w/ POC & Solenoid Valve	◊	•				
Motorized Valve w/ POC (2)	◊	◊	◊	◊	◊	◊
Motorized w/ POC & Motorized w/o POC	◊	◊	•	•	•	•
Normally Open Vent Valve	◊	•	•	•	•	•

¹ Standard for full modulation; optional on select parallel positioning systems

Note: A separate oil circulating pump set is required for all DE and DEG burners. The burner mounted unit is an oil input metering device only.

Standard Ratings

D Series

DE - DEG: #2-6 Oil, Gas/Oil Configuration

	Gas Input MBH	#2-6 Oil Input GPH	BHP @ 80% Eff.	Blower Motor HP "S" ¹	Blower Motor HP "P" ²	Separate Compressor Module Motor HP 3 PH.	Oil Metering System Motor HP 3 PH.	Standard Gas Train Pipe Size (in.)	Gas Pressure Required ("w.c.") ³	Nozzle Line Heater (kw)	
Model No. & Frame Size											
D-42-1	4,200	28	100	3	3	3	1/2	2	9.2	3	208 / 230 / 460 / 3
D-54-1	5,400	36	129	3	5	3	1/2	2	15.3	3	
D-63-1	6,550	44	156	5	5	3	1/2	2	21.6	3	
D-84-2	8,400	56	200	5	7 1/2	3	1/2	2 1/2	18.0	5	
D-105-2	10,500	70	250	7 1/2	10	3	1/2	3	16.0	5	
D-145-3	15,000	100	357	15	15	3	1/2	3	2 PSI	5	
D-175-4	17,500	114	417	20	20	5	1/2	3	5 PSI	5	
D-210-5	21,000	140	500	20	25	5	3/4	3	5 PSI	7	230 / 460 / 3
D-252-6	25,200	168	600	25	30	7 1/2	3/4	3	5 PSI	10	
D-300-6	30,000	200	714	40	40	7 1/2	3/4	3	10 PSI	10	460 / 3
D-315-6	31,500	210	750	-	60	7 1/2	3/4	3	10 PSI	10	
D-336-7	33,600	224	800	-	60	7 1/2	3/4	3	10 PSI	10	
D-378-8	37,800	252	900	-	75	15	1	4	10 PSI	10	
D-420-8	42,000	280	1,000	-	75	15	1	4	10 PSI	10	

¹ Use model "S" up to 1.5" w.c. furnace pressure, consult the factory for higher pressures

² Use model "P" up to 4.0" w.c. furnace pressure, consult the factory for higher pressures

³ Standard gas pressures only, lower gas supply pressure configurations available for New York City requirements

Input is based on fuel BTU content, listed furnace pressure and altitude of 2,000 feet or less. If altitude > 2,000 feet and < 8,000 feet, derate capacity 4% per 1,000 feet over 2,000. Consult factory for higher altitudes. If furnace pressure exceeds listed value, derate capacity 5% for every 0.5" w.c. of pressure in excess of stated. Consult factory if derate exceeds 20%. Gas input is based on natural gas with 1,000 BTU/cu.ft. and 0.60 gravity. For total pressure at manifold, add furnace pressure. Oil input is based on 150,000 BTU/gal. Consult factory for 50 Hz. applications.

Standard Dimensions

D Series

DE - DEG: #2-6 Oil, Gas/Oil Configuration

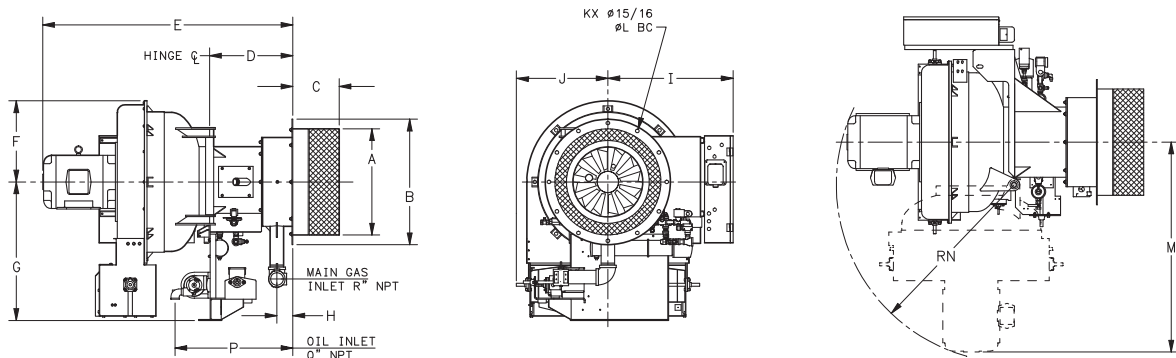

		Burner Frame Size & Model Number									
DIM		Size 1	Size 2		Size 3	Size 4	Size 5	Size 6		Size 7	Size 8
		42-63	84	105	145	175	210	252-300	315	336	378-420
Length in inches											
Overall length	E	45 3/4	44 5/8	45 5/8	56 7/8	60	64 3/4	66 3/8	69 3/8	68 1/2	73 7/8
Width in inches											
Center line to right side	I	21 5/8	23 7/8	23 7/8	24 3/4	25 1/4	32 3/8	32 3/8	32 3/8	32 3/8	36 7/8
Center line to left side	J	17 7/8	17 5/8	17 5/8	21	22	23 3/4	23 3/4	23 3/4	23 3/4	28
Height in inches											
Center line to top	F	13	15	15	15	15	21	21	21	21	23
Center line to bottom	G	23 3/4	25 3/8	25 3/8	30 1/8	31 7/8	35 7/8	37 3/8	37 3/8	38 7/8	39 7/8
Dry oven dimensions in inches											
Diameter of dry oven	A	15 7/8	19	19	22	27 1/2	27 1/2	31 1/2	31 1/2	34 5/8	34 5/8
Depth of dry oven	C	9	10	10	12	12	12	15	15	18	18
Mounting flange dimensions in inches											
Diameter	B	22	24	24	27	32 1/2	32 1/2	37	37	40	42
Flange to hinge	D	18	18	18	21 1/2	21 1/2	21 1/2	22	22	22	24
Diameter of bolt circle	L	20 1/2	22	22	25	30 1/2	30 1/2	35	35	38	40
Number of mounting holes	K	8	12	12	12	12	12	12	12	12	12
Hinge swing dimensions in inches											
Center line to outer hinge clearance	M	32 3/4	35 3/8	36 3/8	45	50 5/8	54 3/8	56 7/8	59 7/8	60 5/8	69 1/8
Hinge swing radius	N	27 3/8	29	30	37 3/8	41 1/4	46	47 1/2	50 1/4	50 1/4	55 5/8
Oil inlet dimensions in inches											
Diameter of oil inlet	Q	3/4	1 1/4	1 1/4	1 1/4	1 1/4	1 1/4	1 1/4	1 1/4	1 1/4	1 1/4
Mounting flange to oil inlet	P	17 7/8	27	27	30 1/2	30 1/2	30 1/2	31	31	30 7/8	33 3/4
Gas inlet dimensions in inches											
Diameter of gas inlet	R	2	2 1/2	2 1/2	3	3	3	4	4	4	4
Mounting flange to gas inlet	H	3 5/8	3 5/8	3 5/5	4 1/8	4 1/8	4 1/8	4 5/8	4 5/8	4 5/8	3 7/8

Accompanying dimensions, while sufficiently accurate for layout purposes, must be confirmed for construction.

Technical Data

D Series

<30 PPM Low NOx Configuration (LNDG, LNDLG)

3.36 - 42.0 MM BTU/H NG; 24 - 300 GPH #2 OIL

UL listed with choice of NFPA, CSD-1, GAP, and FM for U.S. or Canadian units

Standard equipment:	Combustion Control System options:	Fuel options:
3450 RPM motor, panel signal lights (Power On, Main Fuel, Ignition, Flame Failure), FGR, dry oven and gasket, combustion air proving switch, high fire air proving switch, 120/1/60 control circuit, burner mounted panel, hinged blast tube with right-hand swing. Gas and gas/oil units only: butterfly rate control valve, high/low gas pressure switches, two gas shutoff cocks, main gas regulator, shipped loose gas train.	Parallel Positioning Combustion Control System with O ₂ Trim and Variable Frequency Drive (VFD)	Main Fuel: Natural gas (LNDG), or Combination gas/ #2 oil - air atomized (LNDLG). Igniter Fuel: Natural gas and/or propane. Fuel Changeover Switch: Combination gas/oil units only (LNDLG).

Series Features

◊ *Optional Feature*

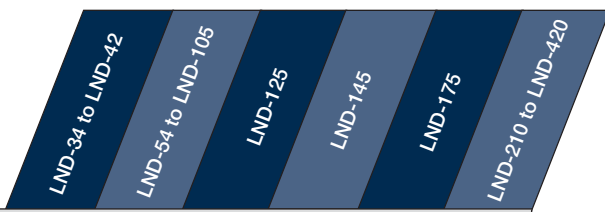

Flame Safeguard							
UV Scanner	•	•	•	•	•	•	•
Mode of Operation							
Full Modulation Firing	•	•	•	•	•	•	•
Auto-Manual Firing Rate Control	• ¹	• ¹	• ¹	• ¹	• ¹	• ¹	• ¹
Ignition							
Gas/Electric Pilot and Ignition Transformer	•	•	•	•	•	•	•
Oil Components							
Oil Solenoid Valve	•	•	•	•	•	•	•
3-Way Motorized POC Valve	◊	◊	◊	◊	◊	◊	•
Atomizing Air Proving Switch	•	•	•	•	•	•	•
Low Oil Pressure Switch	◊	◊	•	•	•	•	•
Burner Mounted Integral Oil/Air System	•	•	•				
Burner Mounted Oil Metering System				•	•	•	•
Separately Mounted Air Compressor Module				•	•	•	•
Gas Components							
Motorized Valve w/o POC & Solenoid Valve	•						
Motorized Valve w/ POC & Solenoid Valve	◊	•					
Motorized Valve w/ POC (2)	◊	◊	◊	◊	◊	◊	◊
Motorized w/ POC & Motorized w/o POC	◊	◊	•	•	•	•	•
Normally Open Vent Valve	◊	◊	•	•	•	•	•

¹ Standard for full modulation; optional on select parallel positioning systems

Note: A separate oil circulating pump set is required for all LNDLG burners. The burner mounted unit is an oil input metering device only.

Standard Ratings

D Series

LNDG - LNDLG: Gas, Gas/Oil Configuration

	Gas Input MBH	#2 Oil Input GPH	BHP @ 80% Eff.	Blower Motor HP	Integral Oil/Air System Motor HP 3 Phase	Separate Compressor Module Motor HP 3 Phase	Oil Metering System Motor HP 3 Phase	Standard Gas Train Pipe Size (in.)	Gas Pressure Required ("w.c.) ¹	Furnace Pressure ("w.c.)	FGR Line Piping (in.)
Model No. & Frame Size											
LND-34-1	3,360	24	80	3	1	-	-	1 1/2	19.86	5.2	6
LND-42-1	4,200	30	100	5	1	-	-	2	15.82	5.2	6
LND-54-1	5,400	38	125	5	1	-	-	2	2 PSI	5.2	6
LND-63-2	6,550	45	150	5	1	-	-	2 1/2	14.87	5.2	6
LND-74-2	7,350	53	175	7 1/2	1	-	-	2 1/2	20.71	5.2	6
LND-84-2	8,400	60	200	10	1	-	-	3	2 PSI	5.2	6
LND-105-3	10,500	75	250	15	2	-	-	3	19.56	5.2	6
LND-125-3	12,600	90	300	15	2	-	-	3	2 PSI	5.2	8
LND-145-4	15,000	105	350	20	-	5	1/2	3	2 PSI	5.2	8
LND-175-5	17,500	120	400	25	-	5	1/2	3	3 PSI	5.2	8
LND-210-6	21,000	150	500	30	-	5	3/4	3	3 PSI	5.2	8
LND-252-6	25,200	180	600	40	-	7 1/2	3/4	3	10 PSI	5.2	10
LND-300-6.5	30,000	215	714	60	-	7 1/2	3/4	3	10 PSI	5.2	10
LND-315-7	31,500	225	750	60	-	7 1/2	3/4	3	10 PSI	5.2	10
LND-336-8	33,600	240	800	75	-	15	1	3	10 PSI	5.2	10
LND-378-8	37,800	270	900	75	-	15	1	4	10 PSI	5.2	10
LND-420-8	42,000	300	1,000	75	-	15	1	4	10 PSI	5.2	10

208 / 230 / 460 / 3

230 / 460 / 3

460 / 3

¹ Standard gas pressures only, consult the factory for lower gas pressures

Input is based on fuel BTU content, listed furnace pressure and altitude of 2,000 feet or less. If altitude > 2,000 feet and < 8,000 feet, derate capacity 4% per 1,000 feet over 2,000. Consult factory for higher altitudes. If furnace pressure exceeds listed value, derate capacity 5% for every 0.5" w.c. of pressure in excess of stated. Consult factory if derate exceeds 20%. Gas input is based on natural gas with 1,000 BTU/cu.ft. and 0.60 gravity. For total pressure at manifold, add furnace pressure. Oil input is based on 140,000 BTU/gal. Consult factory for 50 Hz. applications.

Standard Dimensions

D Series

LNDG - LNDLG: Gas, Gas/Oil Size 1 - 4 Configuration

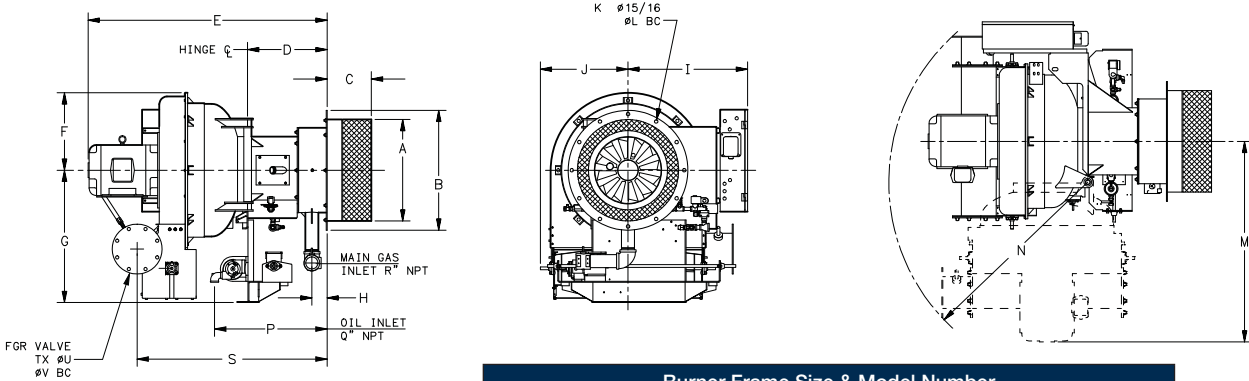

Burner Frame Size & Model Number

DIM	Burner Frame Size & Model Number						
	34	42	54	63 - 84	105 - 125	145	
Length in inches							
Overall length	E	46 5/8	46 5/8	46 5/8	48 1/4	56 7/8	60
Width in inches							
Center line to right side	I	21 5/8	21 5/8	21 5/8	23 7/8	24 3/4	25 1/4
Center line to left side	J	17 7/8	17 7/8	17 7/8	17 7/8	20 5/8	21 5/8
Height in inches							
Center line to top	F	13 5/8	13 5/8	13 5/8	15	15	15
Center line to bottom	G	24 5/8	24 5/8	24 5/8	25 3/8	30 1/8	31 7/8
Dry oven dimensions in inches							
Diameter of dry oven	A	15 7/8	15 7/8	15 7/8	19	22	27 1/2
Depth of dry oven	C	9	9	9	10	12	12
Mounting flange dimensions in inches							
Diameter	B	22	22	22	24	27	32 1/2
Flange to hinge	D	18	18	18	18	21 1/2	21 1/2
Diameter of bolt circle	L	20 1/2	20 1/2	20 1/2	22	25	30 1/2
Number of mounting holes	K	8	8	8	12	12	12
Hinge swing dimensions in inches							
Center line to outer hinge clearance	M	36 1/8	36 1/8	36 1/8	38 5/8	45	50 5/8
Hinge swing radius	N	36 7/8	36 7/8	36 7/8	39 1/4	47 3/8	49 5/8
Oil inlet dimensions in inches							
Diameter of oil inlet	Q	3/4	3/4	3/4	1 1/4	1 1/4	1 1/4
Mounting flange to oil inlet	P	17 7/8	17 7/8	17 7/8	27	30 1/2	30 1/2
Gas inlet dimensions in inches							
Diameter of gas inlet	R	2	2	2	2 1/2	3	3
Mounting flange to gas inlet	H	3 7/8	3 7/8	3 7/8	3 5/8	4 1/8	4 1/8
Flue gas recirculation (FGR) in inches							
Center line of FGR to mounting flange	S	41 1/2	41 1/2	41 1/2	42 3/4	47 7/8	50
Number of mounting holes	T	16	16	16	16	16	16
Bolt hole diameter	U	3/4	3/4	7/8	7/8	7/8	7/8
Bolt circle diameter	V	7 1/2	7 1/2	9 1/2	9 1/2	9 1/2	11 3/4

Accompanying dimensions, while sufficiently accurate for layout purposes, must be confirmed for construction.

Standard Dimensions

D Series

LNDG - LNDLG: Gas, Gas/Oil Size 5 - 8 Configuration

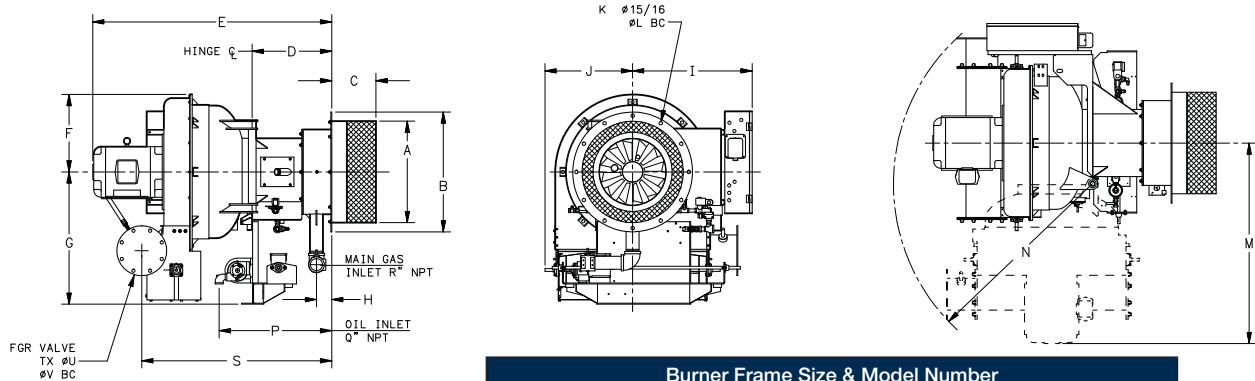

Burner Frame Size & Model Number

DIM	Burner Frame Size & Model Number						
	Size 5	Size 6		Size 6.5	Size 7	Size 8	
	175	210	252	300	315	336 - 420	
Length in inches							
Overall length	E	64 3/4	66 3/8	66 3/8	69 3/8	68 1/2	73 7/8
Width in inches							
Center line to right side	I	32 3/8	32 3/8	32 3/8	32 3/8	32 3/8	36 7/8
Center line to left side	J	23 3/4	23 3/4	23 3/4	23 3/4	23 3/4	28
Height in inches							
Center line to top	F	21	21	21	21	21	23
Center line to bottom	G	35 7/8	37 3/8	37 3/8	37 3/8	38 7/8	39 7/8
Dry oven dimensions in inches							
Diameter of dry oven	A	27 1/2	31 1/2	31 1/2	31 1/2	34 5/8	34 5/8
Depth of dry oven	C	12	15	15	15	18	18
Mounting flange dimensions in inches							
Diameter	B	32 1/2	37	37	37	40	42
Flange to hinge	D	21 1/2	22	22	22	22	24
Diameter of bolt circle	L	30 1/2	35	35	35	38	40
Number of mounting holes	K	12	12	12	12	12	12
Hinge swing dimensions in inches							
Center line to outer hinge clearance	M	54 3/8	56 7/8	56 7/8	59 7/8	60 5/8	69 1/8
Hinge swing radius	N	54	58	58	59	59 5/8	68 5/8
Oil inlet dimensions in inches							
Diameter of oil inlet	Q	1 1/4	1 1/4	1 1/4	1 1/4	1 1/4	1 1/4
Mounting flange to oil inlet	P	30 1/2	31	31	31	30 7/8	33 3/4
Gas inlet dimensions in inches							
Diameter of gas inlet	R	3	4	4	4	4	4
Mounting flange to gas inlet	H	4 1/8	4 5/8	4 5/8	4 5/8	4 5/8	3 7/8
Flue gas recirculation (FGR) in inches							
Center line of FGR to mounting flange	S	51 1/2	51 5/8	52 7/8	54 3/8	53 1/2	63
Number of mounting holes	T	16	16	24	24	24	24
Bolt hole diameter	U	7/8	7/8	1	1	1	1
Bolt circle diameter	V	11 3/4	11 3/4	14 1/4	14 1/4	14 1/4	14 1/4

Accompanying dimensions, while sufficiently accurate for layout purposes, must be confirmed for construction.



WYMBS INC

Hev-e-Oil Burner Distributors

2395 WASHINGTON AVENUE - BRONX, NY 10458

(718) 295-3500 FAX (718) 295-4526

WWW.WYMBS.COM

EST. 1938

**INDUSTRIAL
COMBUSTION**

351 21st Street, Monroe, WI 53566 USA

608.325.3141 · info@ind-comb.com

ind-comb.com