

OIL PUMP SYSTEM

SIMPLEX & DUPLEX TECHNOLOGY



**INDUSTRIAL
COMBUSTION**

Simplex No. 2 thru 6 Oil

75 to 1600 GPH

Industrial Combustion Simplex Oil Pump Systems are designed to deliver No. 2 thru No. 6 fuel oil to any operation which requires an oil supply. These systems are assembled, wired, and tested units suitable for light or heavy fuel oils. Capacities range from 75 to 1600 gallons per hour. Direct drive gear type pumps, with integral relief valves are used for No. 2 and 5 oils. No. 6 oil systems use a screw type pump with a separate relief valve. Pump rating is based on 50 psi discharge pressure, other pressures are available, please consult the factory. Suction should not exceed 15 inches Hg vacuum. All pumps incorporate mechanical seals and are driven by an open drip proof motor or an optional TEFC motor.

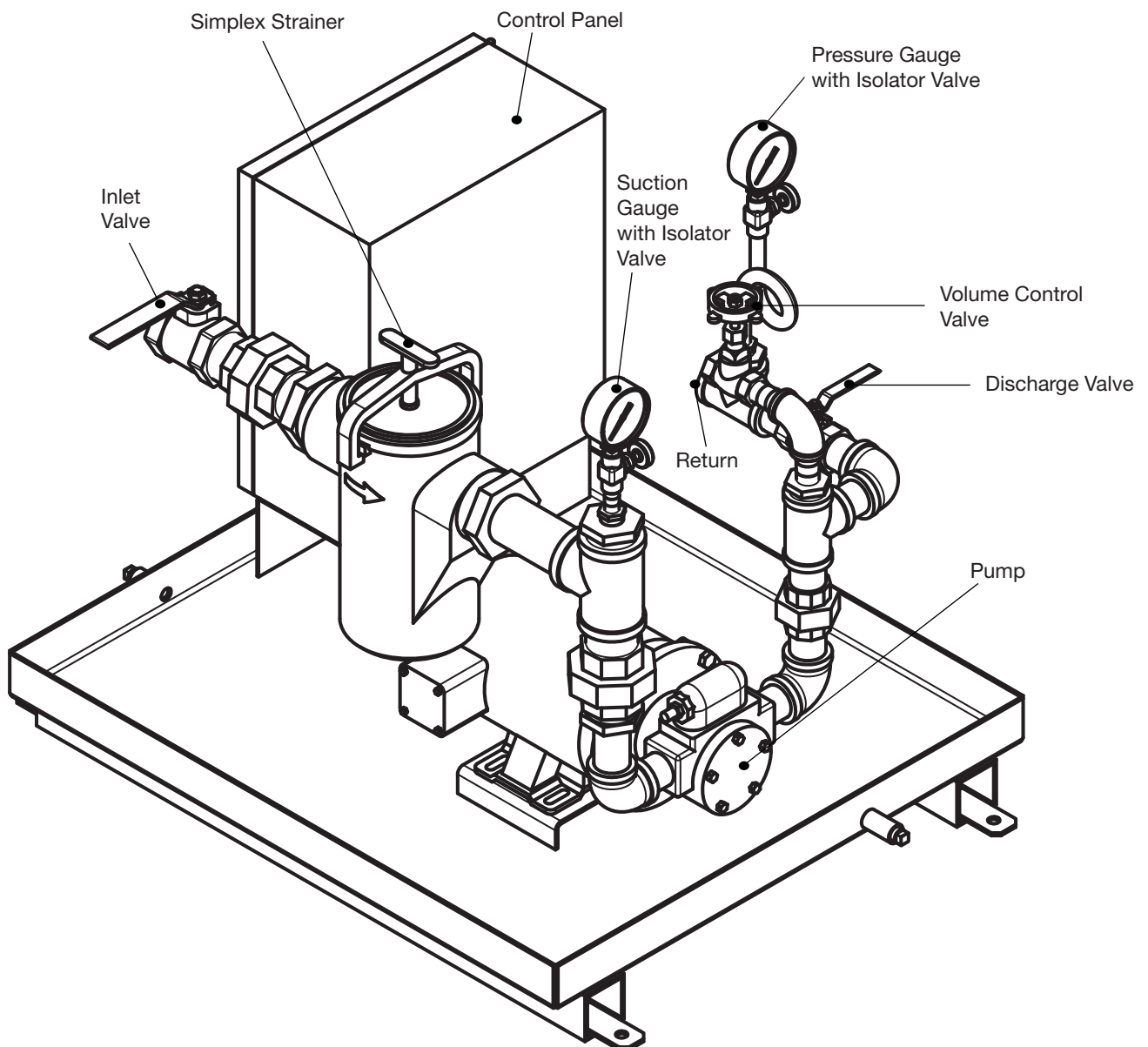

Model Number SP-1-300-2 shown above is "typical". Consult the factory for job specific dimension diagrams.

Standard Equipment & Specifications

Controls

- 120/1/60 control circuit
- Control panel mounted to base
- Motor starter
- Signal light (power on)
- Switch (on-off)

Suction Side

- Manual valve
- Simplex strainer
- Vacuum gauge with isolator

Discharge Side

- Manual valve
- Volume control valves
- Pressure gauge with isolator

Other Equipment

- Drip pan base with drain
- Pump and Motor
- Pump relief valve (integral on No. 2-5 oil)
- Check valve (optional)

Ordering Information

- Oil pump system number
- Oil grade and viscosity
- Flow rate
- Electrical characteristics

Simplex No. 2 thru 6 Oil Capacities

Oil Pump System	Part No.	Maximum Discharge	Standard Voltage		Motor HP 1725	Pipe Size (in.)			Drip Pan (in.)		Pump Type
			115/230/1/60	208/230/460/3/60		Suction	Discharge	Strainer	Length	Width	
NO. 2 OIL											
SP-1-75-2	700-00032	75	X		1/2	1	3/4	1	28	24	GEAR
SP-1-150-2	700-00033	150	X		1/2	1	3/4	1	28	24	GEAR
SP-1-250-2	700-00034	250		X	1/2	1	1	1	28	24	GEAR
SP-1-400-2	700-00035	400		X	3/4	1 1/2	1	1 1/2	28	24	GEAR
SP-1-600-2	700-00036	600		X	3/4	1 1/2	1 1/2	1 1/2	28	24	GEAR
SP-1-900-2	700-00037	900		X	1	2	1 1/2	2	32	28	GEAR
SP-1-1200-2	700-00038	1200		X	1 1/2	2	1 1/2	2	32	28	GEAR
SP-1-1600-2	700-00039	1600		X	2	2 1/2	2	2 1/2	38	30	GEAR
NO. 5 OIL											
SP-1-75-5	700-00040	75		X	1/2	1	3/4	1	28	24	GEAR
SP-1-150-5	700-00041	150		X	1/2	1 1/2	1 1/2	1 1/2	28	24	GEAR
SP-1-200-5	700-00042	200		X	1/2	1 1/2	1 1/2	1 1/2	28	24	GEAR
SP-1-300-5	700-00043	300		X	1/2	1 1/2	1 1/2	1 1/2	32	28	GEAR
SP-1-500-5	700-00044	500		X	3/4	2	1 1/2	2	32	28	GEAR
SP-1-900-5	700-00046	900		X	1	2	2	2	38	30	GEAR
SP-1-1500-5	700-00047	1500		X	2	2 1/2	2	2 1/2	42	32	GEAR
NO. 6 OIL											
SP-1-130-6	700-00048	130		X	1/2	1 1/2	1 1/2	1 1/2	28	24	SCREW
SP-1-200-6	700-00049	200		X	1/2	1 1/2	1 1/2	1 1/2	32	28	SCREW
SP-1-300-6	700-00050	300		X	1/2	2	1 1/2	2	42	32	SCREW
SP-1-500-6	700-00051	500		X	3/4	2	2	2	42	32	SCREW
SP-1-900-6	700-00052	900		X	1 1/2	3	2 1/2	3	42	32	SCREW
SP-1-1400-6	700-00053	1400		X	2	3	2 1/2	3	46	34	SCREW

Motor HP and RPM are subject to change based on pump selection. Overall specifications are subject to change based on application.

Simplex No. 5 and 6 Oil

75 to 1500 GPH

Industrial Combustion Simplex Oil Pump and Heater Systems are designed to deliver No. 5 or No. 6 fuel oil to any type of operation which requires a heated oil supply. The package performs three functions that are essential to efficient heavy oil operation: transferring oil from the supply and boosting the pressure to that required by the burner(s), straining oil to remove solids which would increase wear on pumps, valves and nozzles, and temperature regulation to control fuel oil viscosity. Capacities range from 75 to 1500 gallons per hour.

The oil heater is a tubular type design steam heater used where maintenance of the oil outlet temperature is important. Cross baffles direct oil flow around heating tubes resulting in efficient heat transfer rates. Stratified flow of oil is eliminated and tube coking is materially reduced.

Direct drive gear type pumps with integral relief valves are used for No. 5 oil. Screw type pumps with separate relief valves are used for No. 6 oil systems. Suction should not exceed 15 inches Hg vacuum. All pumps incorporate mechanical seals and are driven by an open drip proof motor or an optional TEFC motor.

The Simplex Oil Pump and Heater Systems are assembled, wired, and tested units, mounted on a welded drip pan steel base.

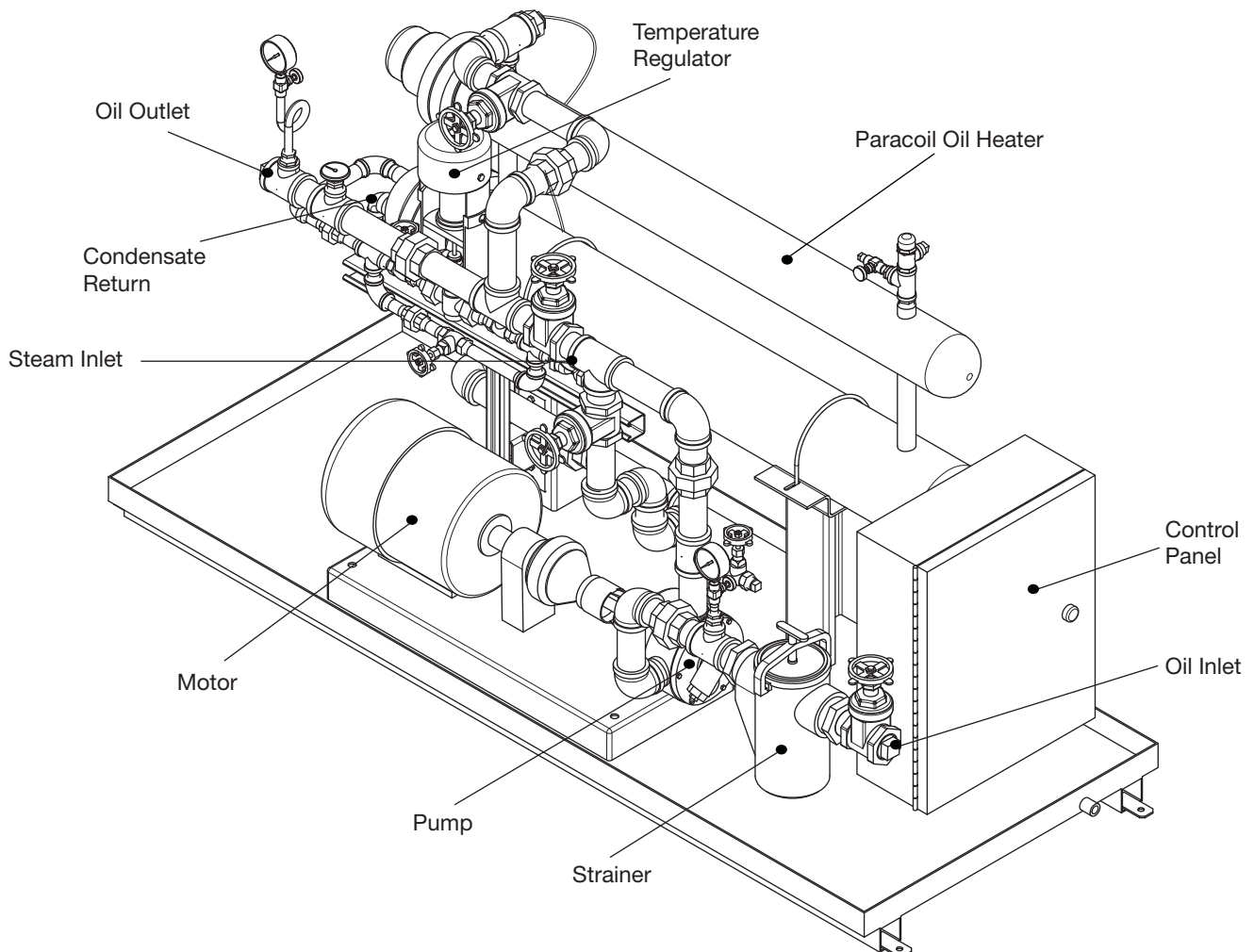

Model Number SPS-1-400-5 shown above is "typical". Consult the factory for job specific dimension diagrams.

Standard Equipment & Specifications

Controls

- 120/1/60 control circuit
- Control panel mounted to base
- Motor starter
- Signal light (power on)
- Switch (on-off)

Suction Side

- Manual valve
- Simplex strainer
- Vacuum gauge with isolator

Discharge Side

- Manual valve
- Volume control valves
- Pressure gauge with isolator
- Steam heat exchanger with:
 - Oil temperature regulator
 - Steam strainer
 - Steam trap
 - Steam globe valve
 - Heat exchanger relief valve
 - Manual vent valve
 - Thermometer 50°/-300°F

Other Equipment

- Drip pan base with drain
- Pump and motor
- Pump relief valve (integral on No. 2-5 oil)
- Check valve (optional)

Ordering Information

- Oil pump system number
- Oil grade and viscosity
- Flow rate
- Electrical characteristics

No. 5 Fuel Oil - Pump & Heater System - 80° - 180°F Rise

System Model No.		Maximum Oil Discharge Capacity GPH	Steam Req. lbs. / hr.	Motor HP 1725 RPM	Oil Pipe Size (in.)		Steam Pipe Size (in.)		Approx. Drip Pan (in.)	
Oil Pump	Steam Pressure				Suction	Discharge	Strainer (Sup.)	Trap (Disch.)	Length	Width
SPH75-5-	5-	75	29.7	1/2	1	3/4	1/2	1/2	48	24
	10-		30.0				1/2			
	50-		31.2				1/2			
	100-		32.4				1/2			
SPH150-5-	5-	150	59.5	1/2	1 1/2	1 1/2	3/4	1/2	48	24
	10-		60.0				1/2			
	50-		62.5				1/2			
	100-		64.8				1/2			
SPH200-5-	5-	200	79.4	1/2	1 1/2	1 1/2	3/4	1/2	72	24
	10-		80.0				3/4		48	
	50-		83.4				1/2		48	
	100-		86.4				1/2		48	
SPH300-5-	5-	300	119.1	1/2	1 1/2	1 1/2	1	1/2	72	28
	10-		120.0				3/4		72	
	50-		125.1				1/2		54	
	100-		129.6				1/2		54	
SPH500-5-	5-	500	198.5	3/4	2	1 1/2	1	1/2	72	28
	10-		200.0				3/4		72	
	50-		208.5				1/2		54	
	100-		216.0				1/2		54	
SPH900-5-	5-	900	357.3	1	2	2	1 1/2	3/4	72	30
	10-		360.0				1		72	
	50-		375.3				3/4		57	
	100-		388.8				3/4		72	
SPH1500-5-	5-	1500	595.5	2	2 1/2	2	1 1/2	3/4	96	32
	10-		600.0				1 1/2		96	
	50-		625.5				1		72	
	100-		648.0				3/4		63	

No. 6 Fuel Oil - Pump & Heater System - 80° - 225°F Rise

System Model No.		Maximum Oil Discharge Capacity GPH	Steam Req. lbs. / hr.	Motor HP 1725 RPM	Oil Pipe Size (in.)		Steam Pipe Size (in.)		Approx. Drip Pan (in.)	
Oil Pump	Steam Pressure				Suction	Discharge	Strainer (Sup.)	Trap (Disch.)	Length	Width
SPH130-6-	10- 50- 100-	130	64.2	1/2	1 1/2	1 1/2	1/2	1/2	72	24
			67.2				1/2	72		
			69.2				1/2	48		
SPH200-6-	10- 50- 100-	200	98.8	1/2	1 1/2	1 1/2	3/4	1/2	72	28
			103.4				1/2	72		
			106.6				1/2	54		
SPH300-6-	10- 50- 100-	300	148.2	1/2	2	1 1/2	1	1/2	72	32
			155.1				1/2	72		
			159.9				1/2	63		
SPH500-6-	10- 50- 100-	500	247.0	3/4	2	2	1	3/4	96	32
			258.5				3/4	72		
			266.5				1/2	72		
SPH900-6-	50- 100-	900	465.3	1 1/2	3	2 1/2	1	1/2	96	32
			479.7				1	72		
SPH1400-6-	50- 100-	1400	723.8	2	3	2 1/2	1	3/4	96	34
			746.2				1	72		

Drip pan is subject to change based on the dimension of the steam heater. Electric heaters are available in lieu of steam heaters, consult factory. Overall specifications may vary based on application.

Duplex No. 2 thru 6 Oil

75 to 1600 GPH

Industrial Combustion Duplex Oil Pump Systems are designed to deliver No. 2 thru No. 6 fuel oil to any operation which requires an oil supply. The duplex system assures a constant supply of filtered oil with the second pump available for standby service. This type of service is essential in applications where systems cannot be interrupted to clean strainers or service pump.

The Duplex Oil Pump Systems are assembled, wired and tested units suitable for light or heavy fuel oil. Capacities range from 75 to 1600 gallons per hour. Direct drive gear pumps, with internal relief valves are used for No. 2 and 5 oils. Screw type pumps with separate relief valves are used for No. 6 oil systems. Pump rating is based on 50 psi discharge pressure, other pressures are available, please consult the factory. Suction should not exceed 15 inches Hg vacuum. All pumps incorporate mechanical seals and are driven by an open drip proof motor or an optional TEFC motor.

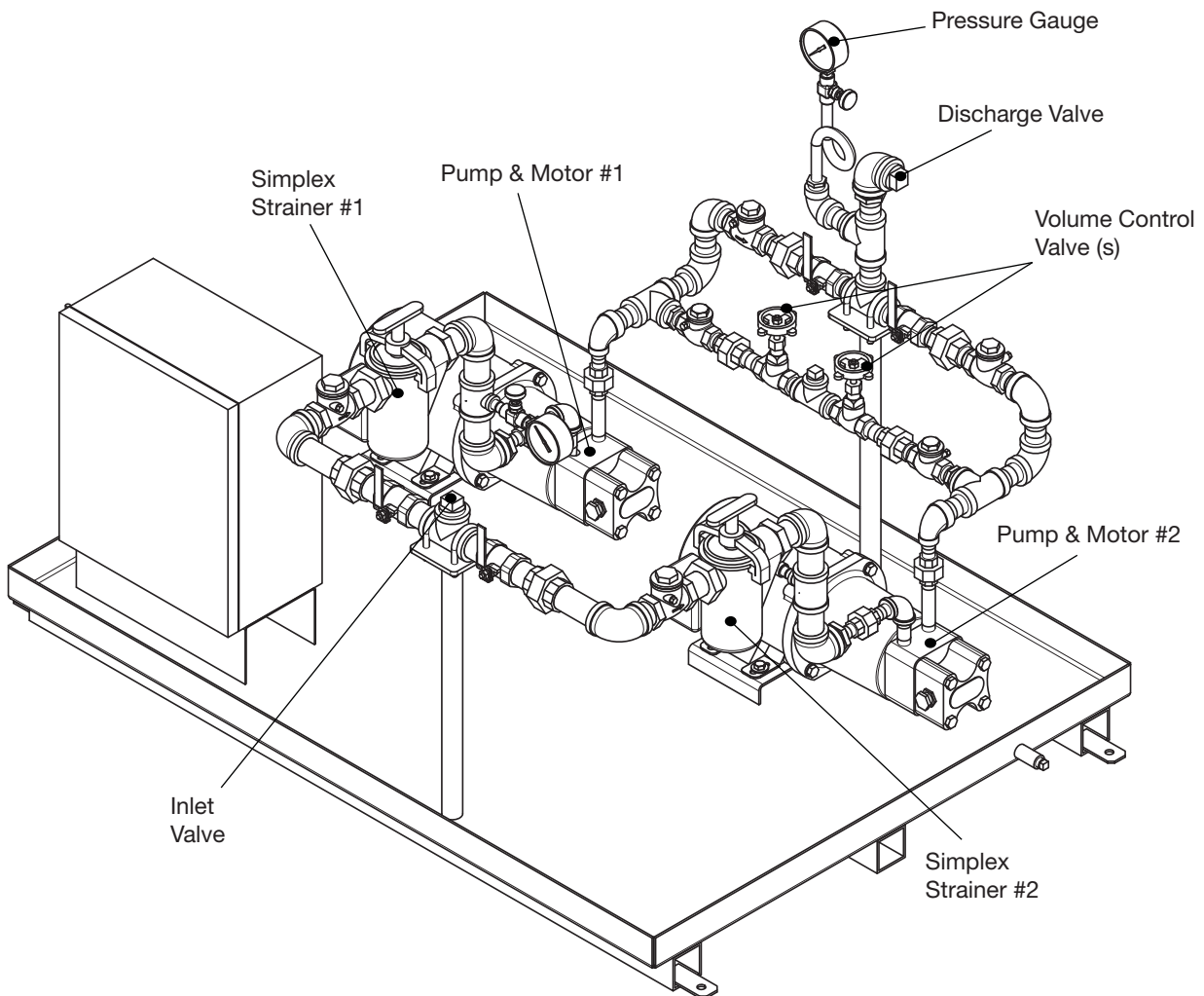

Model Number DP-1-75-2 shown above is "typical". Consult the factory for job specific dimension diagrams.

Standard Equipment & Specifications

Controls

- 120/1/60 control circuit
- Control panel mounted to base
- Motor starter (2)
- Signal lights (pump 1 and 2)
- On-Off and pump selection switch

Suction Side

- Common suction
- Manual valves (2)
- Simplex strainers (2)
- Vacuum gauge with isolators (2)

Discharge Side

- Common discharge
- Manual valves (2)
- Volume control valves (2)
- Pressure gauge with isolator

Other Equipment

- Drip pan base with drain
- Pumps and Motors (2)
- Pump relief valves (integral on No. 2-5 oil) (2)
- Check valves (optional)

Ordering Information

- Oil pump system number
- Oil grade and viscosity
- Flow rate
- Electrical characteristics

Duplex No. 2 thru 6 Oil Capacities

Oil Pump System	Part No.	Maximum Discharge	Standard Voltage		Motor HP 1725 RPM	Pipe Size (in.)			Drip Pan (in.)		Pump Type
			115/230/1/60	208/230/460/3/60		Suction	Discharge	Strainer	Length	Width	
NO. 2 OIL											
DP-1-75-2	700-00054	75	X		1/2	1	3/4	1	48	28	GEAR
DP-1-150-2	700-00055	150	X		1/2	1	3/4	1	48	28	GEAR
DP-1-250-2	700-00056	250		X	1/2	1	1	1	48	28	GEAR
DP-1-400-2	700-00057	400		X	3/4	1 1/2	1	1 1/2	48	28	GEAR
DP-1-600-2	700-00058	600		X	3/4	1 1/2	1 1/2	1 1/2	48	28	GEAR
DP-1-900-2	700-00059	900		X	1	2	1 1/2	2	54	36	GEAR
DP-1-1200-2	700-00060	1200		X	1 1/2	2	1 1/2	2	54	36	GEAR
DP-1-1600-2	700-00061	1600		X	2	2 1/2	2	2 1/2	57	42	GEAR
NO. 5 OIL											
DP-1-75-5	700-00062	75		X	1/2	1	3/4	1	48	28	GEAR
DP-1-150-5	700-00063	150		X	1/2	1 1/2	1 1/2	1 1/2	48	28	GEAR
DP-1-200-5	700-00064	200		X	1/2	1 1/2	1 1/2	1 1/2	48	28	GEAR
DP-1-300-5	700-00065	300		X	1/2	1 1/2	1 1/2	1 1/2	54	36	GEAR
DP-1-500-5	700-00066	500		X	3/4	2	1 1/2	2	54	36	GEAR
DP-1-900-5	700-00068	900		X	1	2	2	2	57	42	GEAR
DP-1-1500-5	700-00069	1500		X	2	2 1/2	2	2 1/2	63	46	GEAR
NO. 6 OIL											
DP-1-130-6	700-00070	130		X	1/2	1 1/2	1 1/2	1 1/2	48	28	SCREW
DP-1-200-6	700-00071	200		X	1/2	1 1/2	1 1/2	1 1/2	54	36	SCREW
DP-1-300-6	700-00072	300		X	1/2	2	1 1/2	2	63	46	SCREW
DP-1-500-6	700-00073	500		X	3/4	2	2	2	63	46	SCREW
DP-1-900-6	700-00074	900		X	1 1/2	3	2 1/2	3	63	46	SCREW
DP-1-1400-6	700-00075	1400		X	2	3	2 1/2	3	68	50	SCREW

Motor HP and RPM are subject to change based on pump selection. Overall specifications may vary based on application.

Duplex No. 5 and 6 Oil

75 to 1500 GPH

Industrial Combustion Duplex Oil Pump and Heater Systems are designed to deliver No. 5 or No. 6 fuel oil to any operation which requires a heated oil supply. The package performs three functions that are essential to efficient heavy oil operation: transferring oil from the supply and boosting the pressure to that required by the burner(s), straining oil to remove solids which would increase wear on pumps, valves and nozzles, and temperature regulation to control fuel oil viscosity. Capacities range from 75 to 1500 gallons per hour.

The duplex system assures a constant supply of heated oil for combustion with the second pump available for standby service. This type of service is essential in applications where systems cannot be interrupted to clean strainers or service pumps.

The oil heater is a tubular type design steam heater used where maintenance of the oil outlet temperature is important. Cross baffles direct oil flow around heating tubes resulting in efficient heat transfer rates. Stratified flow of oil is eliminated and tube coking is materially reduced.

Direct drive gear type pumps with integral relief valves are used for No. 5 oil. Screw type pumps with separate relief valves are used for No. 6 oil systems. Suction should not exceed 15 inches Hg vacuum. All pumps incorporate mechanical seals and are driven by an open drip proof motor or an optional TEFC motor.

The Duplex Oil Pump and Heater Systems are assembled, wired, and tested units, mounted on a welded drip pan steel base.

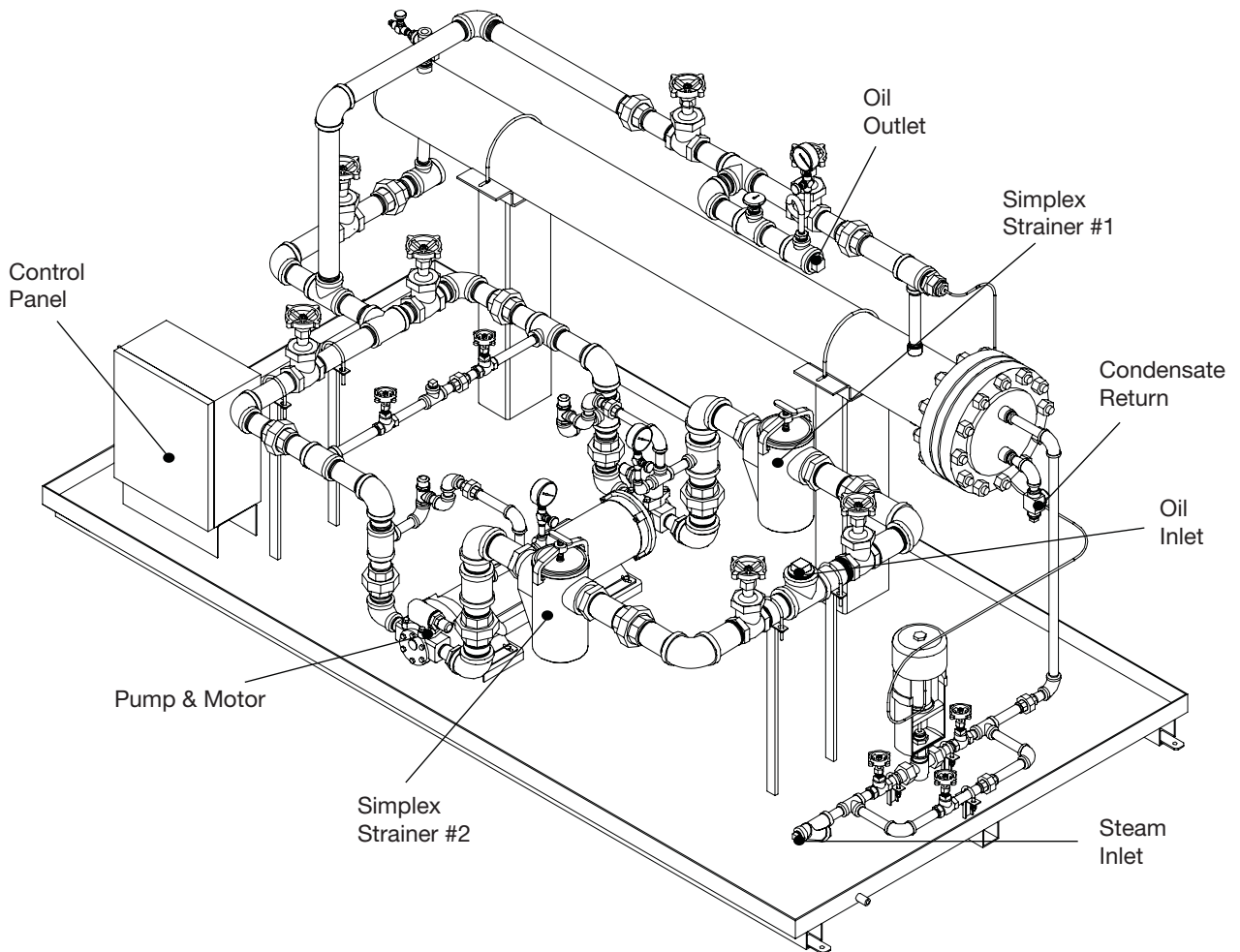

Model Number SPS-1-400-5 shown above is "typical". Consult the factory for job specific dimension diagrams.

Standard Equipment & Specifications

Controls

- 120/1/60 control circuit
- Control panel mounted to base
- Motor starters (2)
- Signal lights (pump 1 and 2)
- On-Off and pump selection switch

Discharge Side

- Manual valves (2)
- Common discharge
- Volume control valves (2)
- Pressure gauge with isolator
- Steam heat exchanger with:
 - Oil temperature regulator
 - Steam strainer
 - Steam trap
 - Steam globe valve
 - Heat exchanger relief valve
 - Manual vent valve
 - Thermometer 50°/-300°F

Other Equipment

- Drip pan base with drain
- Pumps and motors (2)
- Pump relief valve (integral on No. 2-5 oil) (2)
- Check valve (optional)
- Electric pre-heater (optional)

Suction Side

- Common suction
- Manual valves (2)
- Simplex strainers (2)
- Vacuum gauge with isolators (2)

Ordering Information

- Oil pump system number
- Oil grade and viscosity
- Flow rate
- Electrical characteristics

No. 5 Fuel Oil - Pump & Heater System - 80° - 180°F Rise

System Model No.		Maximum Oil Discharge Capacity GPH	Steam Req. lbs. / hr.	Motor HP 1725 RPM	Oil Pipe Size (in.)		Steam Pipe Size (in.)		Approx. Drip Pan (in.)	
Oil Pump	Steam Pressure				Suction	Discharge	Strainer (Sup.)	Trap (Disch.)	Length	Width
DPH75-5-	5-	75	29.7	1/2	1	3/4	1/2	1/2	48	28
	10-		30.0				1/2			
	50-		31.2				1/2			
	100-		32.4				1/2			
DPH150-5-	5-	150	59.5	1/2	1 1/2	1 1/2	3/4	1/2	48	28
	10-		60.0				1/2			
	50-		62.5				1/2			
	100-		64.8				1/2			
DPH200-5-	5-	200	79.4	1/2	1 1/2	1 1/2	3/4	1/2	72	28
	10-		80.0				3/4		48	
	50-		83.4				1/2		48	
	100-		86.4				1/2		48	
DPH300-5-	5-	300	119.1	1/2	1 1/2	1 1/2	1	1/2	72	36
	10-		120.0				3/4		72	
	50-		125.1				1/2		54	
	100-		129.6				1/2		54	
DPH500-5-	5-	500	198.5	3/4	2	1 1/2	1 1/2	1/2	72	36
	10-		200.0				3/4		72	
	50-		208.5				1/2		54	
	100-		216.0				1/2		54	
DPH900-5-	5-	900	357.3	1	2	2	1 1/2	3/4	72	42
	10-		360.0				1		72	
	50-		375.3				3/4		57	
	100-		388.8				3/4		72	
DPH1500-5-	5-	1500	595.5	2	2 1/2	2	1 1/2	3/4	96	46
	10-		600.0				1 1/2		96	
	50-		625.5				1		72	
	100-		648.0				3/4		63	

No. 6 Fuel Oil - Pump & Heater System - 80° - 225°F Rise

System Model No.		Maximum Oil Discharge Capacity GPH	Steam Req. lbs. / hr.	Motor HP 1725 RPM	Oil Pipe Size (in.)		Steam Pipe Size (in.)		Approx. Drip Pan (in.)	
Oil Pump	Steam Pressure				Suction	Discharge	Strainer (Sup.)	Trap (Disch.)	Length	Width
DPH130-6-	10-50-100-	130	64.2	1/2	1 1/2	1 1/2	1/2	1/2	72	28
			67.2				1/2	1/2	72	
			69.2				1/2	1/2	48	
DPH200-6-	10-50-100-	200	98.8	1/2	1 1/2	1 1/2	3/4	1/2	72	36
			103.4				1/2	1/2	72	
			106.6				1/2	1/2	54	
DPH300-6-	10-50-100-	300	148.2	1/2	2	1 1/2	1	1/2	72	46
			155.1				1/2	1/2	72	
			159.9				1/2	1/2	63	
DPH500-6-	10-50-100-	500	247.0	3/4	2	2	1	3/4	96	46
			258.5				3/4	1/2	72	
			266.5				1/2	1/2	72	
DPH900-6-	50-100-	900	465.3	1 1/2	3	2 1/2	1	1/2	96	46
			479.7				1	1/2	72	
DPH1400-6-	50-100-	1400	723.8	2	3	2 1/2	1	3/4	96	52
			746.2				1	3/4	72	

Drip pan is subject to change based on the dimension of the steam heater. Electric heaters are available in lieu of steam heaters, consult factory. Overall specifications may vary based on application.

System Specifications

Fuel Oil Pump Systems

General

Furnish one Fuel Oil Pump Set, designed to pump _____ GPH of No. _____ oil at _____ PSI at not more than _____ ft. total lift including friction. Set shall be a factory engineered and fabricated assembly, as manufactured by Industrial Combustion Model No. _____, and shall include the following components:

Oil Strainer

_____ simplex _____ duplex cast iron strainer located at oil inlet.

Pump - Electric Driven

Heavy duty pump rated _____ GPH at _____ PSI, operating at 1750 RPM. Pumps for No. 6 oil to be screw type.

Motor

Motor, rated _____ HP _____ Phase _____ Cycle _____, 1750 RPM drip-proof suitable for operation on _____ volts. Provided with magnetic across-the-line starter having low voltage and overload protection. Provide "On-Off" selector switch. Motor to be wired to starter.

Volume Control

A stainless steel needle valve shall be provided to permit reducing oil flow rate below the pump maximum capacity.

Valves

In addition to steam and oil shut-off valves, needle type shut-off valves shall be provided for each gauge.

Accessories

Accessories shall include pressure gauge, thermometer, vacuum gauge and relief valves for pumps. All pipe, valves and fittings to be assembled and complete system factory pressure tested at 50% above design pressure prior to shipment.

Volume Control

A stainless steel needle valve shall be provided to permit reducing oil flow rate below the pump maximum capacity.

Assembly

All piping to be schedule 40 black iron with nipples, fittings, and unions as required. All valves to be rated at 150 PSI minimum.

Base

Base to be of fabricated steel with drop pan and drain connection.

Fuel Oil Pump and Heater Systems

General

Furnish one Simplex Fuel _____ or Duplex Fuel _____ Oil Pump and Heater System, designed to transfer _____ GPH of _____ (No. 5 or No. 6) oil at _____ PSI with a temperature rise of _____ °F minimum inlet temperature. System, Model No. _____, shall be manufactured by Industrial Combustion and shall include the following components:

Fuel Oil Heater

Shell and tube type Paracoil heater with relief valve, manual vent valve and removable bundle, with capacity to heat _____ GPH No. _____ fuel oil from _____ °F to _____ °F, supplied with _____ PSI saturated steam. Heater shall be controlled by an adjustable temperature regulating valve with a 3-valve by-pass, strainer and a steam trap.

Electric Heater (Optional)

One Electric Heater for start-up service _____ K.W. _____ volts _____ phase with thermostat and contractor, piped in discharge line from steam heater. Maximum input _____ watts per square inch.

Temperature Regulator

Temperature regulating valve, suitable to supply steam requirements of heater, to maintain oil temperature within plus or minus 5°F of that specified. Temperature regulator shall have remote sensing bulb with a separable socket.

Oil Strainer

_____ inch cast iron strainers located at oil inlet. (Two oil strainers will be supplied for Duplex Systems).

Pump - Electric Driven

Heavy duty pump rated _____ GPH at _____ PSI, operating at 1750 RPM. Pumps for No. 6 oil to be screw type. Pumps for No. 5 oil may be gear type. (Two electric driven pumps will be supplied for Duplex Systems.)

Motor

Motor, rated _____ HP _____ Phase _____ Cycle _____. Provided with magnetic across-the-line starter having low voltage and overload protection. Provide "on-off" selector switch. Motor to be wired to starter. (two motors will be supplied for Duplex Systems).

Volume Control

A stainless steel needle valve shall be provided to permit reducing oil flow rate below the pump maximum capacity.

Valves

In addition to steam and oil shut-off valves, needle type shut-off valves shall be provided for each gauge and one for manual air venting and sample withdrawal.

Accessories - Simplex System

Accessories shall include pressure gauge, thermometer, vacuum gauge and relief valve on pump. All pipe, valves and fittings to be assembled and complete system factory pressure tested at 50% above design pressure prior to shipment.

Accessories - Duplex System

Accessories shall include pressure gauges, thermometers, vacuum gauges and relief valves on pumps. Manual valves permit either pump to discharge through heater while remaining pump or strainer is being serviced. All pipe, valves and fittings to be assembled and complete system factory pressure tested at 50% above design pressure prior to shipment.

Assembly

All piping to be schedule 40 black iron with nipples, fittings and unions as required. All valves to be rated 150 PSI minimum.

Base

Base to be of fabricated steel with drop pan and drain connection.

Start-Up & Service Procedures

Inspection

- Check electrical ratings of all components against connected electric power.
- Make certain that motor starter overloads match the rated current values for the connected device.
- Inspect relief valve settings and compare with system specifications.
- Compare component piping with system specifications.
- Compare suction piping with system specifications paying special attention to pipe size and lift (Pump inlet elevation above oil level in tank).

Test

- Close inlet and discharge valves.
- Apply air pressure, (not over 50 PSI) through bleed valve or other gauge opening.
- Check all joints with soap solution. Repair any known leaks.
- Check direction of motor rotation by momentarily lifting starter armature.

Start-Up Procedure

- Make certain ALL valves except atmospheric bleed or vent valves are open.
- If pump is above oil level in tank, prime the inlet piping by pouring oil into strainer body. Replace strainer cover and start pump motor with bypass valve open. If the suction line is long, it may be necessary to prime several times before all air is expelled from suction side of pump.
- Gradually close volume control bypass valve. This will simultaneously increase flow through the system piping loop. The flow rate to the system is controlled by the throttling of the bypass valve. This needle type valve may be operated continuously in a partially open position. All other valves must be operated fully open or fully closed.

Adjustment

- If flow rate to the circulating loop is higher than needed, the discharge pressure may be higher than the system design pressure or higher than the system back pressure valve indicates. The flow rate may be decreased by opening the bypass valve slightly.
- The circulating pump is protected against damage by excess pressure with a relief valve. This valve may be internal, in which case the valve relieves to the pump inlet or it may be an external relief valve piped to the system return. No shut-off valve must be installed downstream from a relief valve.

Service

- Observe all vacuum and pressure gauges regularly. Determine cause for any abnormal change. Vacuum and pressure gauge valves should be closed except when being read.
- Gradual vacuum increase indicates drop in oil level in tank or dirty strainer. Clean strainer when vacuum approaches maximum recommended pump suction. Usually 15 inches of mercury, but may be more or less.



351 21st Street, Monroe, WI 53566 USA
608.325.3141 · info@ind-comb.com
ind-comb.com